

# Rubber **Marine** Fenders



## CONTENTS

1	INTRODUCTION	1-2
2	TYPE APPROVED FENDERS	
	■ HYPER OMEGA (HOM) TYPE	3-6
	■ UPi TYPE	7-10
	■ Pi / HPi TYPE	11-14
	■ PPi TYPE	15-16
	■ LAMBDA TYPE	17-19
	■ LAMBDA.F TYPE	20-22
	■ BETA TYPE	23-25
	■ BETA.F TYPE	26-28
	■ HYPER ACE TYPE	29-32
3	RUBBER LADDER GH-TYPE	33-34
4	ANCHOR BOLT	35
5	ACCESSORIES	36
6	CHAIN SYSTEM	37
7	U-ANCHOR	38
8	OTHER FENDERS	39
9	TECHNICAL DATA	40-41
10	PROJECT REQUIREMENTS FOR DESIGNING FENDER SYSTEM	42

## Go for Value: Optimizing Design, Performance and Cost.

Sumitomo Rubber Industries, Ltd. history goes back in time when Dunlop U.K. established Japan's first modern rubber factory in Kobe in 1909., the company only began production and sale of rubber marine fenders in 1967, Having inherited the industrial manufacturing business of Sumitomo Rubber Industries Ltd, it has over 40 years of experience now and a proven track record in the global marine fender market while keeping pace with the latest advances in technology. We respond rapidly to changes in the market and meet customer needs with cutting-edge technology and optimum solutions, always bearing in mind our motto: "Go for Value: Optimizing Design, Performance and Cost." In tandem to these guiding principles, we take pride to serve our customers conscientiously and with integrity. Best Quality from our Factory.

## The High Quality from our Factory in Japan

With state-of-the-art facilities achieving the high possible product quality, the Kakogawa Plant serves as the production base for Sumitomo Rubber Industries, Hybrid Rubber Products HQS. With a quality management system administered according to ISO9001 standards and a testing protocol compliant with the PIANC 2002 Guidelines for the Design of Fender Systems, high product quality is guaranteed.



## PIANC 2002 "Guidelines for the Design of Fender Systems: 2002"

Guidelines for the design, production and quality management of fender systems, drawn up in 2002 by Working Group-33 of MARCOM (the Maritime Navigation Commission), part of the International Navigation Association (PIANC).

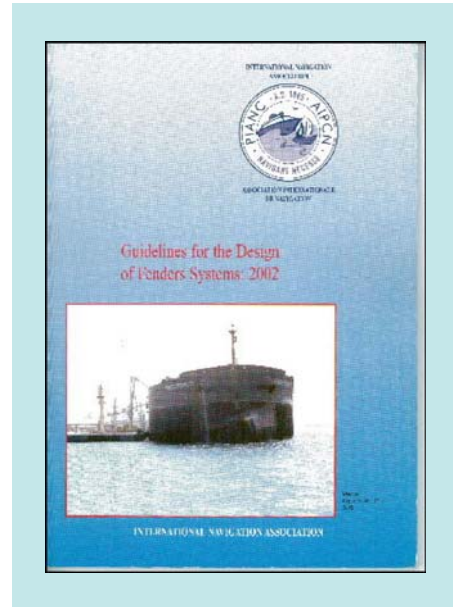

## PIANC 2002, Type Approval & Test Protocols

Purchasers of rubber marine fenders must be sure to buy only from manufacturers that can absolutely guarantee the required level of quality. In September 2009, Sumitomo Rubber Industries obtained the following two certifications:

### Type Approval

Product quality conforming to PIANC 2002 guidelines and attaining 5,000 deflections, while only 3,000 deflections are being specified.

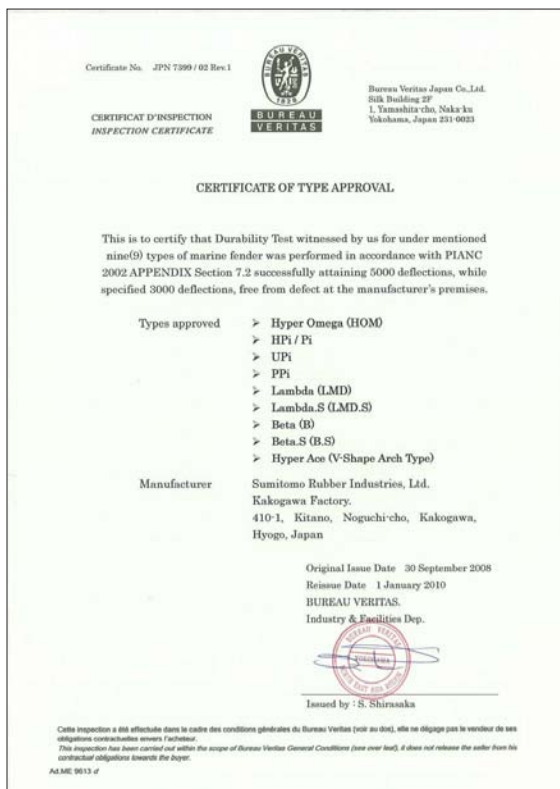

### Compliance with PIANC 2002 Appendix A

Indicates that products are suitable for testing according to the test and inspection methods defined by PIANC 2002 Appendix A



# HYPER OMEGA TYPE



The conical Hyper Omega type fender offers improved performance with prolonged deflection up to 70% as design. This superior product fulfills the demands for both top quality and affordability that characterize today's market.

## Performance

The unique profile of the Hyper Omega was developed using 3D FEM (finite element method) technology, and achieves improved design deflection of 70.0%. One of the world's highest E/R ratios. In comparison to conventional cell or circular Pi type which has a rated deflection of a mere 52.5%, smaller sizes of the fender can be selected for an optimal design in terms of efficiency and thus cost effectiveness in the overall system design. (E/R ratio: Energy/reaction force ratio) Angled compression of up to 7° is achieved without any deficiency in performance.

## Flexible Flange Portion

The flange portion on the steel frame side of the fender, which is thinner than the basement part of the body itself, enables it to have more flexibility toward angular berthing or the flare of the ship, resembling it to a ball joint effect as well as minimizing the bending moment generated onto the steel frame.

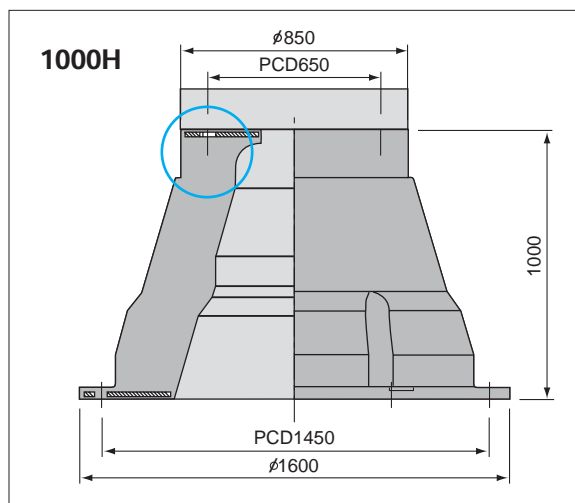

## Shear Resistance and Durability

While conical fenders in general offer superior shear resistance, the Hyper Omega boasts further improved shear resistance as well as durability, thanks to its belt-shaped reinforcement both on the inside and outside of the fender body.

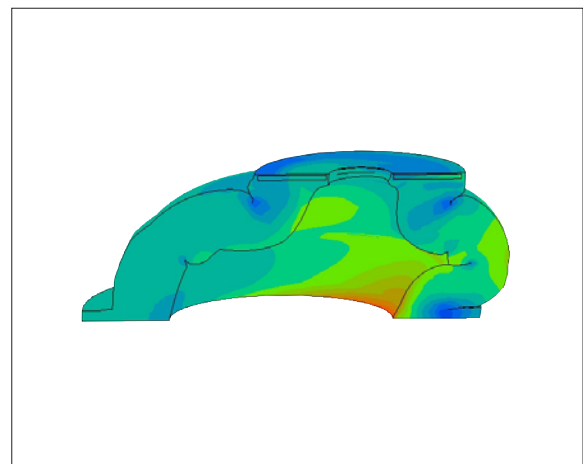
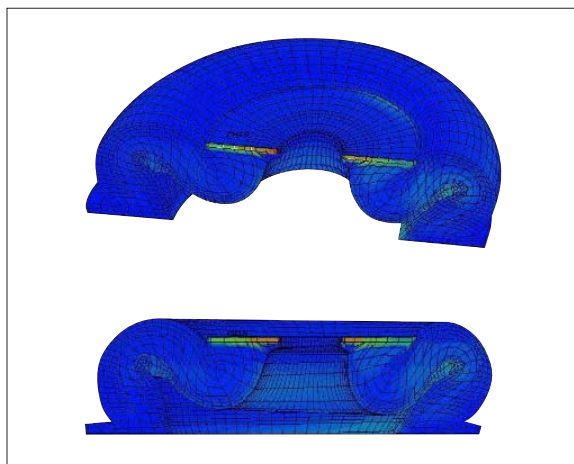



Size & Dimension

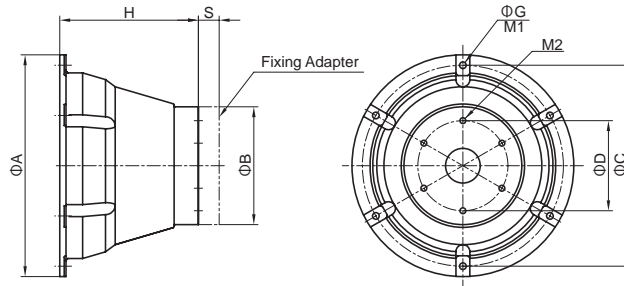

	H [mm]	S [mm]	Φ A [mm]	Φ B [mm]	Φ C [mm]	Φ D [mm]	Φ G [mm]	Anchor Bolt Size & Qty size M1	Fixing Bolt Size & Qty size M2	Weight [kgf]
HOM-400H	400	85	650	340	550	260	32	M22x 4	M20x 4	70
HOM-600H	600	90	980	520	900	390	32	M22x 6	M20x 6	230
HOM-800H	800	120	1,250	680	1,100	520	42	M30x 6	M30x 6	520
HOM-900H	900	135	1,450	765	1,300	585	42	M30x 6	M30x 6	760
HOM-1000H	1,000	150	1,600	850	1,450	650	48	M36x 6	M36x 6	1050
HOM-1150H	1,150	175	1,840	980	1,650	750	55	M42x 6	M42x 6	1680
HOM-1300H	1,300	195	2,000	1,105	1,800	845	55	M48 x 8	M36x 8	2200
HOM-1450H	1,450	220	2,250	1,232.5	2,000	940	58	M48 x 8	M42x 8	3000
HOM-1600H	1,600	240	2,500	1,360	2,250	1,040	58	M48 x 8	M48x 8	4000
HOM-1800H	1,800	270	2,840	1,530	2,560	1,170	73	M64x 8	M56x 8	6200

※Smaller bolt size can be proposed depending on the design condition. ※The data are subject to change without notice.

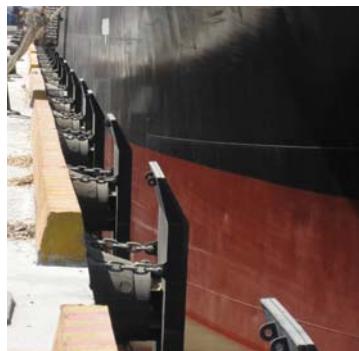
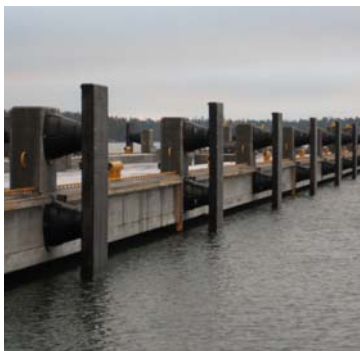



Performance Characteristics

Rubber Compound	X155(1.55)				X140(1.40)				X120(1.20)				X100(1.00)				X80(0.80)			
	70%		72.5%		70%		72.5%		70%		72.5%		70%		72.5%		70%		72.5%	
Fender Height	R (kN)	E (kN-m)	R (kN)	E (kN-m)	R (kN)	E (kN-m)	R (kN)	E (kN-m)	R (kN)	E (kN-m)	R (kN)	E (kN-m)	R (kN)	E (kN-m)	R (kN)	E (kN-m)	R (kN)	E (kN-m)	R (kN)	E (kN-m)
HOM-400H	194	43.4	236	45.5	176	39.2	214	41.1	151	33.6	184	35.2	125	28.0	152	29.4	100	22.4	122	23.5
HOM-600H	438	147	533	154	395	132	481	139	339	113	413	119	282	94.5	343	99.1	226	75.6	275	79.3
HOM-800H	778	347	947	364	703	314	856	329	602	269	733	282	502	224	611	235	401	179	488	188
HOM-900H	984	495	1198	519	889	447	1082	468	762	383	927	402	635	319	773	335	508	255	618	268
HOM-1000H	1215	678	1479	712	1098	613	1336	643	941	525	1145	551	784	438	954	459	627	350	763	367
HOM-1150H	1607	1032	1956	1082	1452	932	1767	977	1244	799	1514	828	1037	666	1262	698	830	533	1010	559
HOM-1300H	2054	1490	2500	1563	1855	1346	2258	1412	1590	1154	1935	1210	1325	962	1613	1009	1060	769	1290	807
HOM-1450H	2555	2068	3109	2169	2308	1868	2809	1959	1978	1601	2407	1679	1649	1334	2007	1400	1319	1067	1605	1120
HOM-1600H	3111	2778	3786	2915	2810	2510	3420	2632	2409	2151	2932	2256	2007	1793	2443	1880	1606	1434	1955	1504
HOM-1800H	3938	3956	4793	4150	3557	3573	4329	3748	3049	3063	3711	3213	2541	2552	3092	2677	2032	2042	2473	2142

R:Reaction Load E:Energy Absorption  
 70%:Rated Deflection 72.5%:Maximum Deflection  
 Tolerance:-10% for min. Energy Absorption and +10% for max Reaction Load  
 ※Special rubber compound can be available depending on design conditions. The range of rubber compound is X60-X155. Please contact us for further detail.  
 ※The data are subject to change without notice.

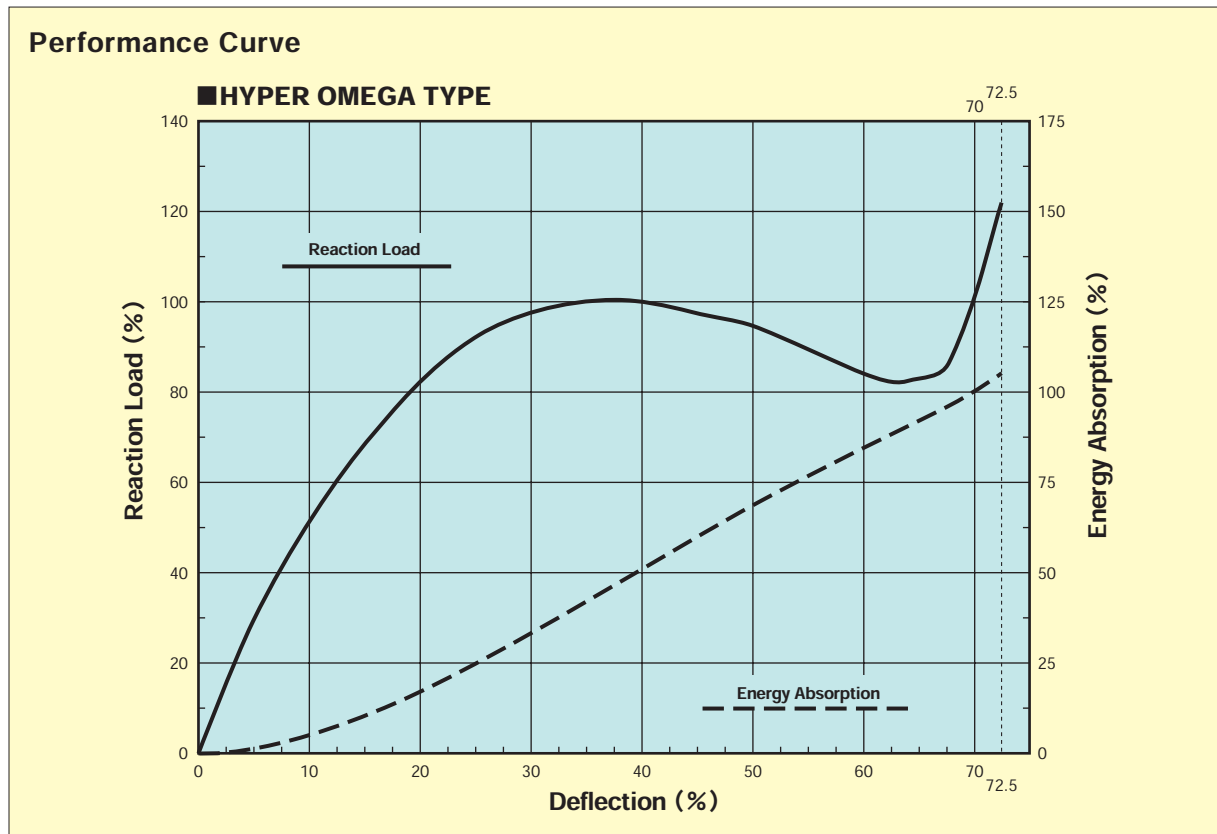

Correction Factor for Angular Compression

Contact Angle(deg)	0	3	5	6	7	8	9	10	15	20
C <sub>E</sub>	1.00	1.00	1.00	1.00	1.00	0.99	0.98	0.97	0.94	0.87
C <sub>R</sub>	1.0	1.0	1.0	1.0	1.0	1.0	1.0	1.0	1.0	1.0



Compression



FEM Analysis

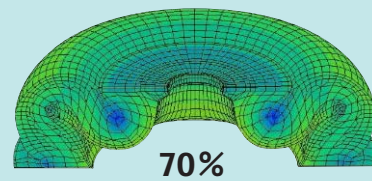
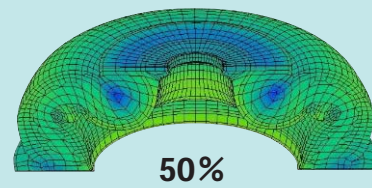
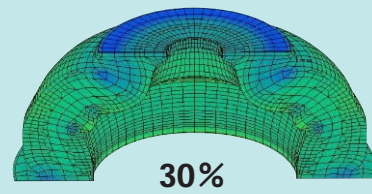
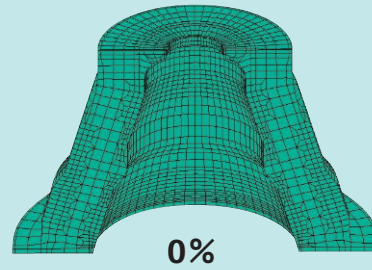

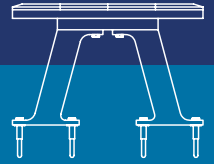

# UPi TYPE

UPi type is the most effective and efficient open-leg fender in the global market with a design deflection of 60%. It features a range of sizes from 600H up to 2500H, capable of accommodating ULCC, Chinamax bulk carrier and Super Post Panamax Container Vessels and other extremely large vessels.

## Performance

UPi is the result of an improved version of the Pi type, and it boasts a design deflection of 60.0%. This improved performance, and in comparison to Pi type, enables the selection of smaller sizes of fenders for a more compact overall system design.

## Various System Design

The rubber legs can be mounted horizontally or vertically in relation to the steel frame, providing the user with choices in configuring the system. In addition, the height, length, and combination of rubber compounds can be selected to suit any design requirements and also to achieve the ideal E/R ratio. (E/R ratio: Energy/reaction force ratio) The fender length can also be adjustable and customized to suit design requirements as the performance is proportional to its length while the rubber compound and height remains unchanged.

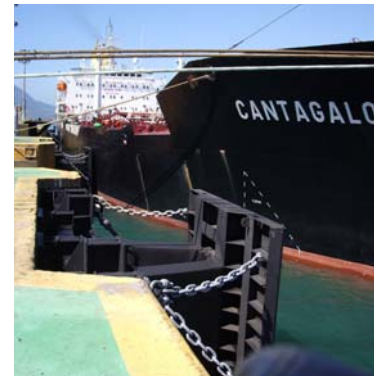





Size & Dimension

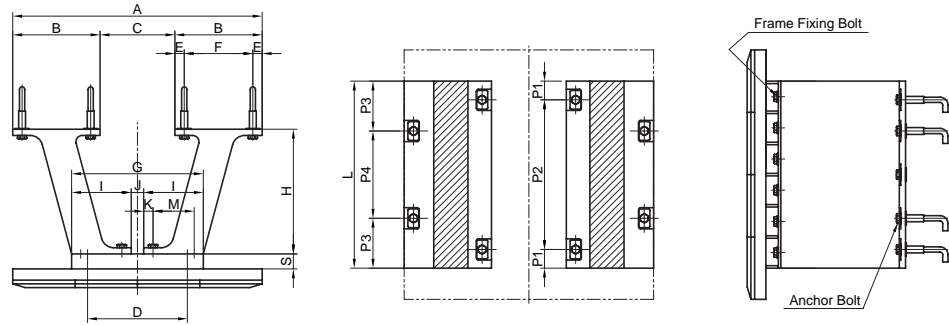

	H [mm]	S [mm]	A [mm]	B [mm]	C [mm]	D [mm]	E [mm]	F [mm]	G [mm]	I [mm]	J [mm]	K [mm]	M [mm]
UPI-400H	400	60	1,030	400	330	420	60	280	530	240	50	50	145
UPI-600H	600	80	1,400	500	400	600	65	370	760	330	100	65	200
UPI-800H	800	100	1,700	600	500	700	70	460	920	410	100	70	270
UPI-1000H	1,000	120	2,000	700	600	800	75	550	1,060	480	100	75	330
UPI-1150H	1,150	140	2,150	730	690	815	75	580	1,130	515	100	75	360
UPI-1250H	1,250	150	2,300	800	700	900	75	650	1,220	560	100	75	400
UPI-1400H	1,400	175	2,600	900	800	1,000	85	730	1,360	630	100	85	460
UPI-1700H	1,700	210	3,100	1,050	1,000	1,200	95	860	1,650	750	150	95	550
UPI-2000H	2,000	250	3,600	1,200	1,200	1,400	100	1,000	1,920	860	200	100	660
UPI-2500H	2,500	300	4,250	1,400	1,450	1,600	100	1,200	2,240	1,020	200	100	810

	H [mm]	L [mm]	P1 [mm]	P2 [mm]	P3 [mm]	P4 [mm]	Anchor Bolt Size & Qty	Fixing Bolt Size	Weight [kg]
UPI-400H	400	1,000	150	700	500	-	M24×6	M24	180
UPI-400H	400	1,500	150	1,200	400	700	M24×8	M24	270
UPI-400H	400	2,000	150	850×2	400	1,200	M24×10	M24	380
UPI-400H	400	2,500	150	1,100×2	600	1,300	M24×10	M24	470
UPI-400H	400	3,000	150	1,350×2	400	1,100×2	M24×12	M24	560
UPI-600H	600	1,000	150	700	500	-	M36×6	M24	415
UPI-600H	600	1,500	150	1,200	750	-	M36×6	M24	760
UPI-600H	600	2,000	250	1,500	400	1,200	M36×8	M24	1,020
UPI-600H	600	2,500	150	1,100×2	600	1300	M36×10	M24	1,280
UPI-600H	600	3,000	150	1,350×2	400	1,100×2	M36×12	M24	1,540
UPI-800H	800	1,000	150	700	500	-	M36×6	M24	755
UPI-800H	800	1,500	150	1,200	400	700	M36×8	M24	1,220
UPI-800H	800	2,000	150	1,500	400	1,200	M36×10	M24	1,640
UPI-800H	800	2,500	150	1,100×2	600	1,300	M36×10	M24	2,060
UPI-800H	800	3,000	150	1,350×2	400	1,100×2	M36×12	M24	2,480
UPI-1000H	1,000	1,000	150	700	500	-	M42×6	M30	1,180
UPI-1000H	1,000	1,500	150	1,200	400	700	M42×8	M30	1,640
UPI-1000H	1,000	2,000	150	1,500	400	1,200	M42×10	M30	2,360
UPI-1000H	1,000	2,500	150	1,100×2	600	1,300	M42×10	M30	2,960
UPI-1000H	1,000	3,000	150	1,350×2	400	1,100×2	M42×12	M30	3,540
UPI-1150H	1,150	1,000	150	700	500	-	M42×6	M30	1,480
UPI-1150H	1,150	1,500	150	1,200	400	700	M42×8	M30	2,060
UPI-1150H	1,150	2,000	150	1,500	400	1,200	M42×10	M30	2,960
UPI-1150H	1,150	2,500	150	1,100×2	600	1,300	M42×10	M30	3,700
UPI-1150H	1,150	3,000	150	1,350×2	400	1,100×2	M42×12	M30	4,440
UPI-1250H	1,250	1,000	150	700	500	-	M42×6	M30	1,585
UPI-1250H	1,250	1,500	150	1,200	400	700	M42×8	M30	2,390
UPI-1250H	1,250	2,000	150	1,500	400	1,200	M42×10	M30	3,380
UPI-1250H	1,250	2,500	150	1,100×2	400	850×2	M42×12	M30	4,240
UPI-1250H	1,250	3,000	150	1,350×2	400	1,100×2	M42×14	M30	5,080
UPI-1400H	1,400	1,000	150	700	500	-	M42×6	M36	1,885
UPI-1400H	1,400	1,500	150	1,200	400	700	M42×8	M36	3,100
UPI-1400H	1,400	2,000	150	1,500	400	1,200	M42×10	M36	4,120
UPI-1400H	1,400	2,500	150	1,100×2	400	850×2	M42×12	M36	5,160
UPI-1400H	1,400	3,000	150	1,350×2	400	1,100×2	M42×14	M36	6,180
UPI-1700H	1,700	1,000	150	700	500	-	M48×6	M36	2,690
UPI-1700H	1,700	1,500	200	1,200	400	700	M48×8	M36	4,125
UPI-1700H	1,700	2,000	200	1,500	400	1,200	M48×10	M36	5,700
UPI-1700H	1,700	2,500	200	1,100×2	400	850×2	M48×12	M36	7,160
UPI-1700H	1,700	3,000	225	1,350×2	400	1,100×2	M48×14	M36	8,600
UPI-2000H	2,000	1,000	150	700	500	-	M48×6	M42	3,560
UPI-2000H	2,000	1,500	200	1,200	400	700	M48×8	M42	5,520
UPI-2000H	2,000	2,000	200	1,500	400	1,200	M48×10	M42	7,480
UPI-2000H	2,000	2,500	200	1,100×2	400	850×2	M48×14	M42	9,440
UPI-2000H	2,000	3,000	225	1,350×2	375	750×3	M48×16	M42	11,400
UPI-2500H	2,500	1,000	150	700	500	-	M64×6	M48	5,500
UPI-2500H	2,500	1,500	200	1,200	400	700	M64×8	M48	8,300
UPI-2500H	2,500	2,000	200	1,500	400	1,200	M64×10	M48	11,100
UPI-2500H	2,500	2,500	200	1,100×2	400	850×2	M64×12	M48	13,900
UPI-2500H	2,500	3,000	225	1,350×2	400	1,100×2	M64×14	M48	16,680

※Space of bolt (P1-P4) can be changed. ※The data are subject to change without notice.



**Performance Characteristics (1.0m Long, one pair of Fender)**

The performance is in proportion to rubber leg length

Compound	CPS (1.55)				CP0 (1.40)				CP1 (1.20)				CP2 (1.00)				CP3 (0.80)			
	60%		62.5%		60%		62.5%		60%		62.5%		60%		62.5%		60%		62.5%	
Fender Height	R (kN)	E (kN-m)	R (kN)	E (kN-m)	R (kN)	E (kN-m)	R (kN)	E (kN-m)	R (kN)	E (kN-m)	R (kN)	E (kN-m)	R (kN)	E (kN-m)	R (kN)	E (kN-m)	R (kN)	E (kN-m)	R (kN)	E (kN-m)
UPi-400H	316	59.1	341	62.4	286	53.4	309	56.4	245	45.8	265	48.4	204	38.1	220	40.2	163	30.5	176	32.2
UPi-600H	474	133	512	140	429	120	463	127	367	103	396	109	306	85.8	330	90.6	245	68.7	265	72.5
UPi-800H	633	236	684	249	571	214	617	226	490	183	529	193	408	153	441	162	326	122	352	129
UPi-1000H	791	369	854	390	714	334	771	353	612	286	661	302	510	238	551	251	408	191	441	202
UPi-1150H	909	489	982	516	821	441	887	466	704	378	760	399	587	315	634	333	469	252	507	266
UPi-1250H	988	577	1067	609	893	521	964	550	765	447	826	472	638	372	689	393	510	298	551	315
UPi-1400H	1107	724	1196	765	1000	654	1080	691	857	561	926	592	714	467	771	493	571	374	617	395
UPi-1700H	1344	1068	1452	1128	1214	964	1311	1018	1041	827	1124	873	867	689	936	728	694	551	750	582
UPi-2000H	1581	1478	1707	1561	1428	1335	1542	1410	1224	1144	1322	1208	1020	954	1102	1007	816	763	881	806
UPi-2500H	1977	2309	2135	2438	1785	2086	1928	2203	1530	1788	1652	1888	1275	1490	1377	1573	1020	1192	1102	1259

R:Reaction Load E:Energy Absorption  
 60%:Rated Deflection 62.5%:Maximum Deflection  
 Tolerance:-10% for min. Energy Absorption and +10% for max Reaction Load  
 ※Special rubber compound can be available depending on design conditions. The range of rubber compound is CP4-CPX. Please contact us for further detail.  
 ※The data are subject to change without notice.

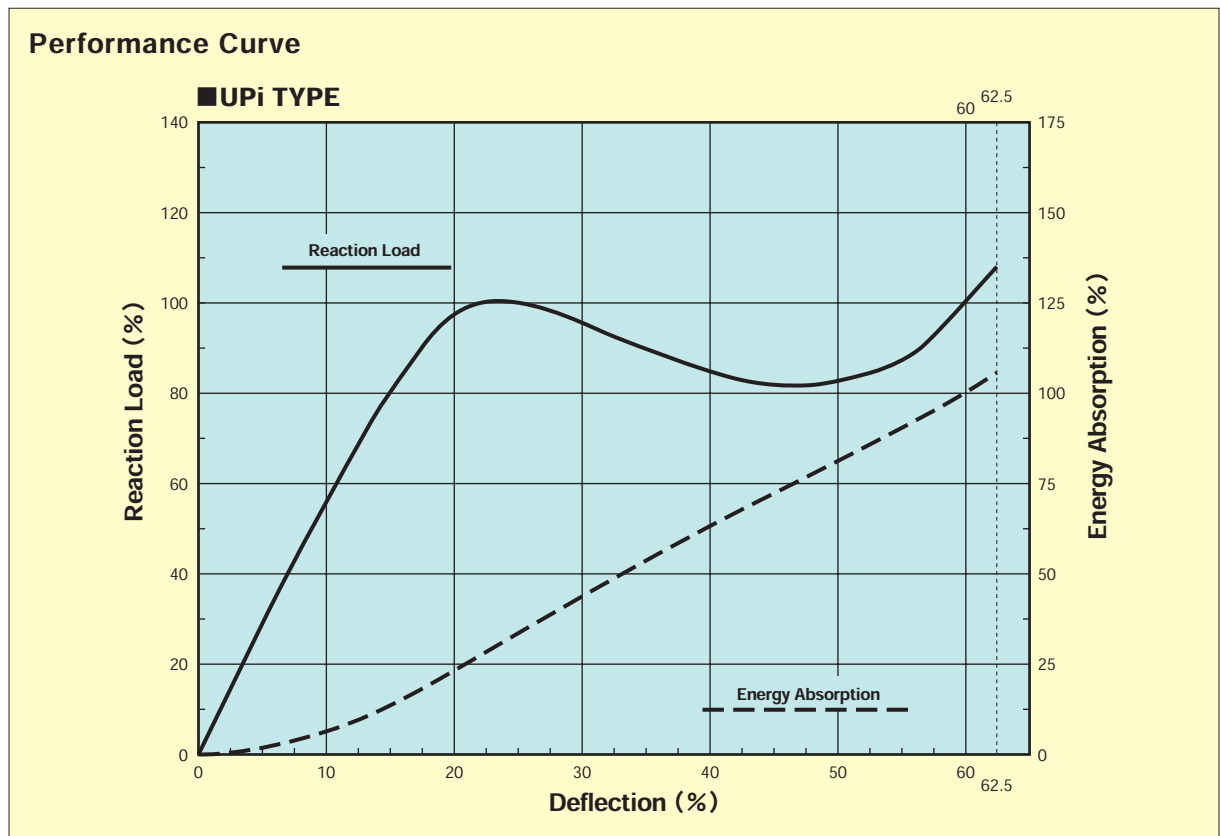



Compression



FEM Analysis

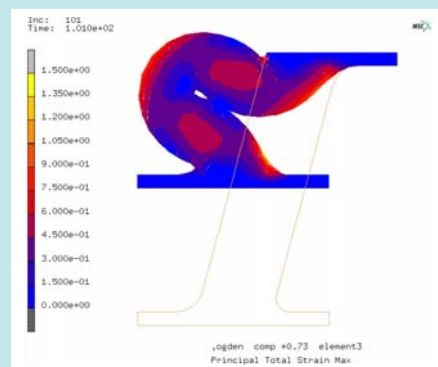
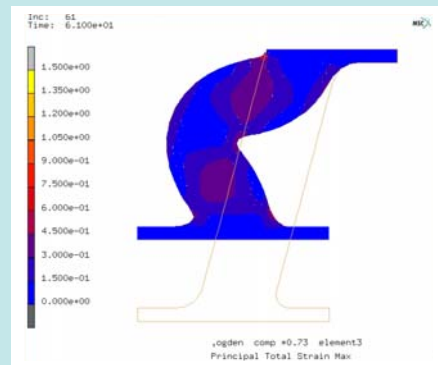
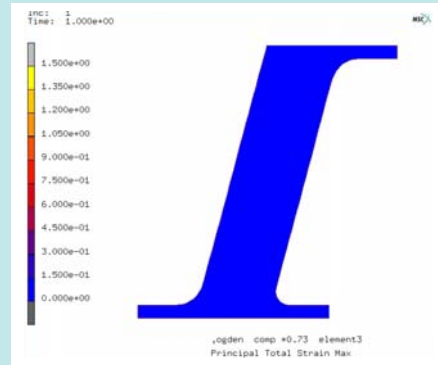

# Pi / HPI TYPE

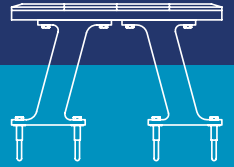

PI Type fender was Sumitomo Rubber's flagship fender system with steel frame when it began its first production in 1971. Ever since, the PI has built up the most thorough and proven track record in the global marine fender market and won many customers praises for its reliability. With the size ranging from 400H to 2500H, suitable fender system can be designed from small to very large ship.

## Performance

The product's distinctive profile, which resembles the Greek letter  $\pi$  (hence its name), achieves design deflection of 52.5%. (Pi-400H to 800H: 50.0%)

## High Durability

The body, which is deflected in an S-curve, features strong shear resistance. The flange portions, reinforced with embedded thick steel plates, on both steel frame side, are firmly installed with fixing bolts and the overall fender system can be used over long periods of time.

## Various System Variations

The rubber legs can be mounted horizontally or vertically in relation to the steel frame, providing the user with choices in configuring the system. In addition, the height, length, and combination of rubber compounds can be selected to suit any design requirements and also to achieve the ideal E/R ratio. (E/R ratio: Energy/reaction force ratio) The fender length can also be adjustable and customized to suit design requirements as the performance is proportional to its length while the rubber compound and height remains unchanged.





Size & Dimension

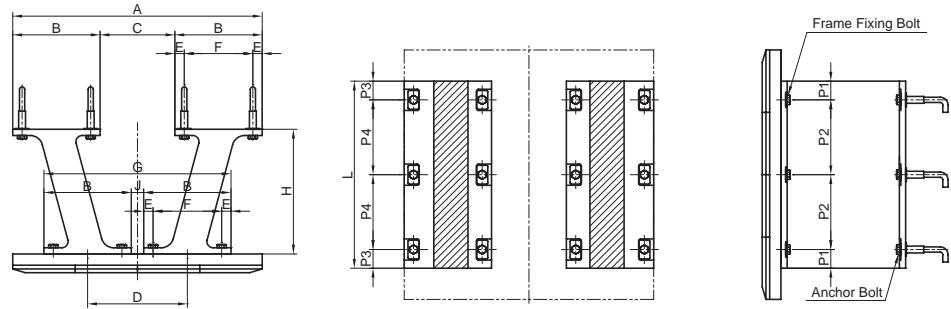

	H [mm]	A [mm]	B [mm]	C [mm]	D [mm]	E [mm]	F [mm]	G [mm]	J [mm]
Pi-400H	400	1,000	300	400	400	60	240	800	-
Pi-600H	600	1,400	500	400	600	65	370	1,100	100
Pi-800H	800	1,700	600	500	700	70	460	1,300	100
HPI-1000H	1,000	2,000	700	600	800	75	550	1,500	100
HPI-1150H	1,150	2,150	730	690	815	75	580	1,560	100
HPI-1250H	1,250	2,300	800	700	900	75	650	1,700	100
HPI-1400H	1,400	2,600	900	800	1,000	85	730	1,900	100
HPI-1700H	1,700	3,100	1,050	1,000	1,200	95	860	2,250	150
HPI-2000H	2,000	3,600	1,200	1,200	1,400	100	1,000	2,600	200
HPI-2500H	2,500	4,250	1,400	1,450	1,600	100	1,200	3,000	200

	H [mm]	L [mm]	P1 [mm]	P2 [mm]	P3 [mm]	P4 [mm]	Anchor Bolt Size & Qty	Fxing Bolt Size & Qty	Weight [kgf]
Pi-400H	400	1,000	150	700	150	700	M30×4	M22×4	285
Pi-400H	400	1,500	150	600 / 600	150	600×2	M30×6	M22×6	480
Pi-400H	400	2,000	150	550 / 600 / 550	150	850×2	M30×6	M22×8	640
Pi-400H	400	2,500	150	550 / 550 / 550 / 550	200	700×3	M30×8	M22×10	695
Pi-400H	400	3,000	150	550 / 500 / 600 / 500 / 550	150	900×3	M30×8	M22×12	960
Pi-600H	600	1,000	150	700	150	700	M36×8	M24×8	460
Pi-600H	600	1,500	150	600 / 600	150	600×2	M36×12	M24×12	775
Pi-600H	600	2,000	150	550 / 600 / 550	150	850×2	M36×12	M24×16	1,120
Pi-600H	600	2,500	150	550 / 550 / 550 / 550	200	700×3	M36×16	M24×20	1,480
Pi-600H	600	3,000	150	550 / 500 / 600 / 500 / 550	150	900×3	M36×16	M24×24	1,820
Pi-800H	800	1,000	150	700	150	700	M36×8	M24×8	825
Pi-800H	800	1,500	150	600 / 600	150	600×2	M36×12	M24×12	1,260
Pi-800H	800	2,000	150	550 / 600 / 550	150	850×2	M36×12	M24×16	1,680
Pi-800H	800	2,500	150	550 / 550 / 550 / 550	200	700×3	M36×16	M24×20	2,100
Pi-800H	800	3,000	150	550 / 500 / 600 / 500 / 550	150	900×3	M36×16	M24×24	2,520
HPI-1000H	1,000	1,000	150	700	150	700	M42×8	M30×8	1,160
HPI-1000H	1,000	1,500	150	600 / 600	150	600×2	M42×12	M30×12	1,770
HPI-1000H	1,000	2,000	150	550 / 600 / 550	150	850×2	M42×12	M30×16	2,360
HPI-1000H	1,000	2,500	150	550 / 550 / 550 / 550	200	700×3	M42×16	M30×20	2,960
HPI-1000H	1,000	3,000	150	550 / 500 / 600 / 500 / 550	150	900×3	M42×16	M30×24	3,570
HPI-1150H	1,150	1,000	150	700	150	700	M42×8	M30×8	1,400
HPI-1150H	1,150	1,500	150	600 / 600	150	600×2	M42×12	M30×12	2,220
HPI-1150H	1,150	2,000	150	550 / 600 / 550	150	850×2	M42×12	M30×16	2,960
HPI-1150H	1,150	2,500	150	550 / 550 / 550 / 550	200	700×3	M42×16	M30×20	3,700
HPI-1150H	1,150	3,000	150	550 / 500 / 600 / 500 / 550	150	900×3	M42×16	M30×24	4,440
HPI-1250H	1,250	1,000	150	700	150	700	M42×8	M36×8	1,680
HPI-1250H	1,250	1,500	150	600 / 600	150	600×2	M42×12	M36×12	2,420
HPI-1250H	1,250	2,000	150	550 / 600 / 550	150	850×2	M42×12	M36×16	3,400
HPI-1250H	1,250	2,500	150	550 / 550 / 550 / 550	200	700×3	M42×16	M36×20	4,260
HPI-1250H	1,250	3,000	150	550 / 500 / 600 / 500 / 550	150	900×3	M42×16	M36×24	5,120
HPI-1400H	1,400	1,000	150	700	150	700	M42×8	M36×8	2,000
HPI-1400H	1,400	1,500	150	600 / 600	150	600×2	M42×12	M36×12	3,065
HPI-1400H	1,400	2,000	150	550 / 600 / 550	150	850×2	M42×12	M36×16	4,055
HPI-1400H	1,400	2,500	150	550 / 550 / 550 / 550	200	700×3	M42×16	M36×20	5,060
HPI-1400H	1,400	3,000	150	550 / 500 / 600 / 500 / 550	150	900×3	M42×16	M36×24	6,080
HPI-1700H	1,700	1,000	150	700	200	600	M48×8	M36×8	3,100
HPI-1700H	1,700	1,500	150	600 / 600	200	550×2	M48×12	M36×12	4,370
HPI-1700H	1,700	2,000	150	550 / 600 / 550	200	800×2	M48×12	M36×16	6,200
HPI-1700H	1,700	2,500	150	550 / 550 / 550 / 550	200	700×3	M48×16	M36×20	7,760
HPI-1700H	1,700	3,000	150	550 / 500 / 600 / 500 / 550	225	850×3	M48×16	M36×24	9,300
HPI-2000H	2,000	1,000	150	700	200	600	M48×8	M42×8	4,200
HPI-2000H	2,000	1,500	150	600 / 600	200	550×2	M48×12	M42×12	6,300
HPI-2000H	2,000	2,000	150	550 / 600 / 550	200	800×2	M48×12	M42×16	8,400
HPI-2000H	2,000	2,500	150	550 / 550 / 550 / 550	200	700×3	M48×16	M42×20	10,500
HPI-2000H	2,000	3,000	150	550 / 500 / 600 / 500 / 550	225	850×3	M48×16	M42×24	12,600
HPI-2500H	2,500	1,000	200	600	150	600	M64×8	M48×8	6,000
HPI-2500H	2,500	1,500	200	550 / 550	200	550×2	M64×12	M48×12	8,505
HPI-2500H	2,500	2,000	200	500 / 600 / 500	200	800×2	M64×12	M48×16	12,000
HPI-2500H	2,500	2,500	200	500 / 550 / 550 / 500	200	700×3	M64×16	M48×20	15,000
HPI-2500H	2,500	3,000	200	500 / 500 / 600 / 500 / 500	225	850×3	M64×16	M48×24	18,000

※Space of bolt (P1-P4) can be changed. ※The data are subject to change without notice.

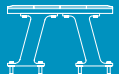

**Performance Characteristics (1.0m Long, one pair of Fender)**

The performance is in proportion to rubber leg length

Compound	CS(1.55)				C0(1.40)				C1(1.20)				C2(1.00)				C3(0.80)			
	50%		52.5%		50%		52.5%		50%		52.5%		50%		52.5%		50%		52.5%	
Height	R (kN)	E (kN-m)	R (kN)	E (kN-m)	R (kN)	E (kN-m)	R (kN)	E (kN-m)	R (kN)	E (kN-m)	R (kN)	E (kN-m)	R (kN)	E (kN-m)	R (kN)	E (kN-m)	R (kN)	E (kN-m)	R (kN)	E (kN-m)
Pi-400H	335	51	358	54	302	46	323	49	259	40	277	43	216	33	231	35	173	26	185	28
Pi-600H	502	115	537	123	453	104	485	111	388	89	415	95	324	74	347	79	259	59	277	63
Pi-800H	669	204	716	218	604	185	646	198	518	158	554	169	432	132	462	141	345	105	369	112

Compound	CPS(1.55)				CP0(1.40)				CP1(1.20)				CP2(1.00)				CP3(0.80)			
	52.5%		55%		52.5%		55%		52.5%		55%		52.5%		55%		52.5%		55%	
Height	R (kN)	E (kN-m)	R (kN)	E (kN-m)	R (kN)	E (kN-m)	R (kN)	E (kN-m)	R (kN)	E (kN-m)	R (kN)	E (kN-m)	R (kN)	E (kN-m)	R (kN)	E (kN-m)	R (kN)	E (kN-m)	R (kN)	E (kN-m)
HPI-1000H	836	347	890	369	755	313	804	332	647	268	689	285	540	224	575	238	432	179	460	190
HPI-1150H	962	458	1025	486	869	414	925	440	745	355	793	377	620	296	660	314	496	237	528	252
HPI-1250H	1045	542	1113	576	944	489	1005	519	809	419	862	445	674	349	718	371	540	280	575	297
HPI-1400H	1171	680	1247	722	1058	614	1127	652	906	526	965	559	755	438	804	465	604	351	643	373
HPI-1700H	1422	1002	1514	1064	1284	905	1367	961	1101	776	1173	824	917	646	977	686	734	517	782	549
HPI-2000H	1673	1387	1782	1473	1511	1253	1609	1331	1295	1074	1379	1141	1079	895	1149	950	863	716	919	760
HPI-2500H	2091	2167	2227	2301	1888	1957	2011	2078	1619	1678	1724	1782	1349	1398	1437	1485	1079	1118	1149	1187

R:Reaction Load E:Energy Absorption  
 50.0%:Rated Deflection 52.5%:Maximum Deflection (Pi TYPE)  
 52.5%:Rated Deflection 55.0%:Maximum Deflection (HPI TYPE)  
 Tolerance:-10% for min. Energy Absorption and +10% for max Reaction Load  
 ※Special rubber compound can be available depending on design conditions. The range of rubber compound is (CP4)-(CPS). Please contact us for further detail.  
 ※The data are subject to change without notice.

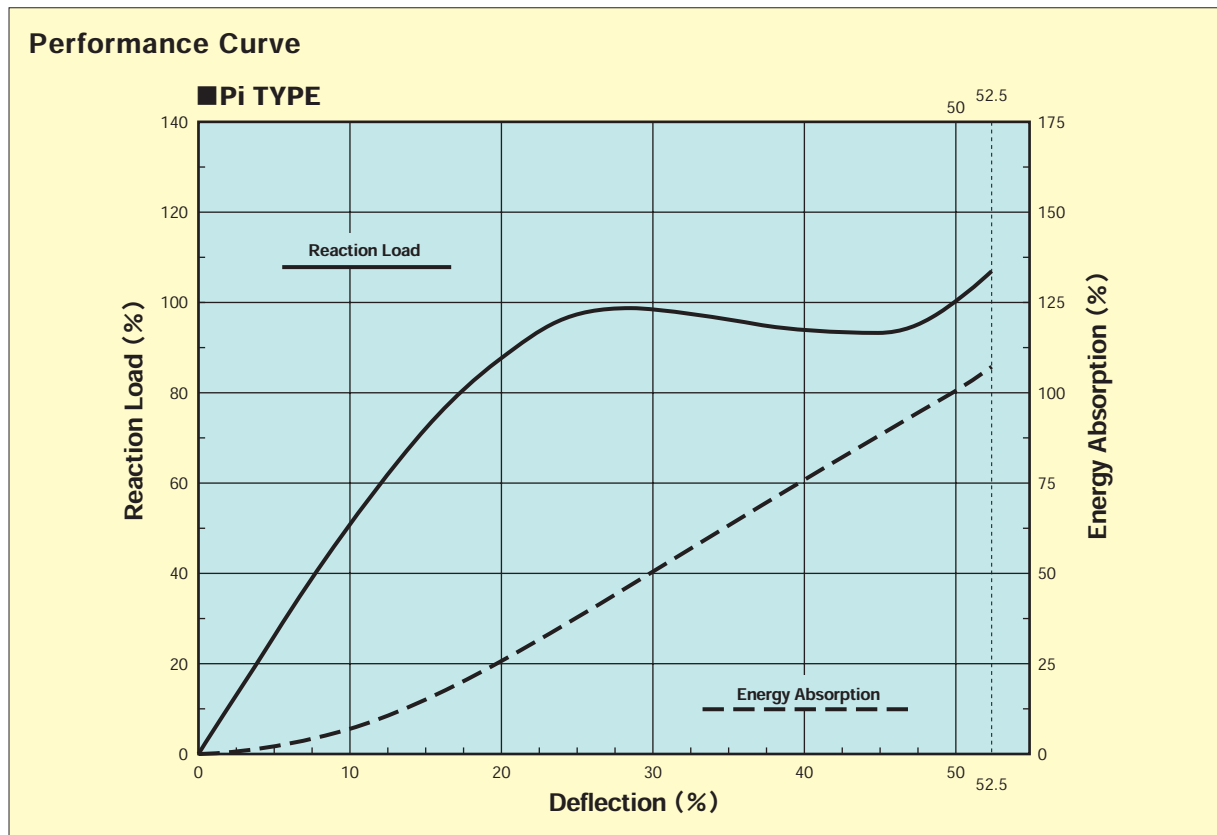

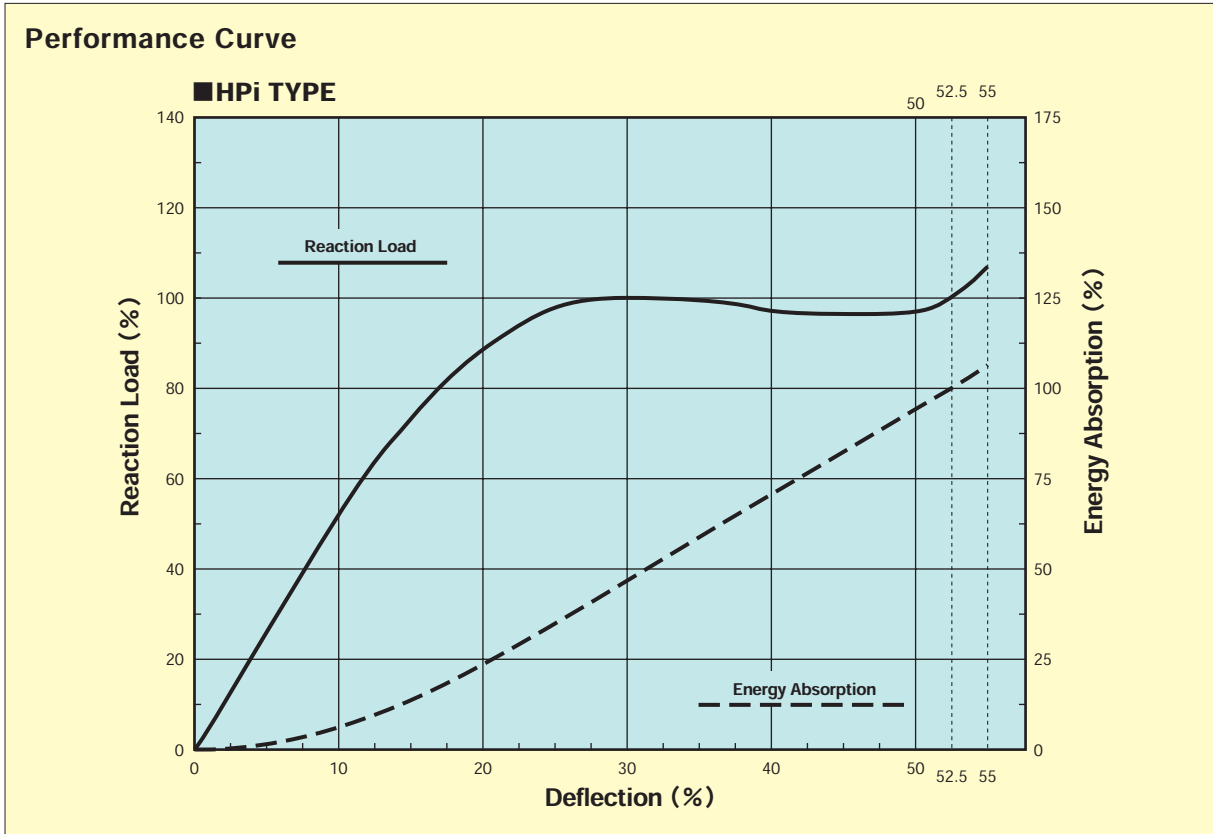

### FEM Analysis

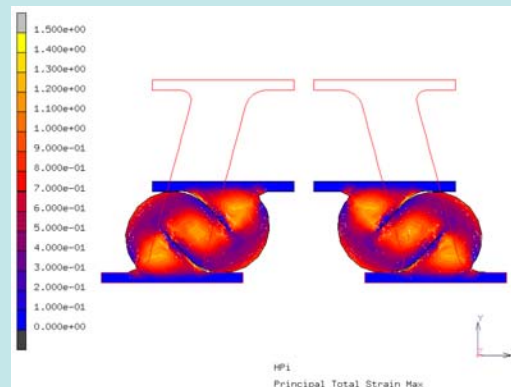
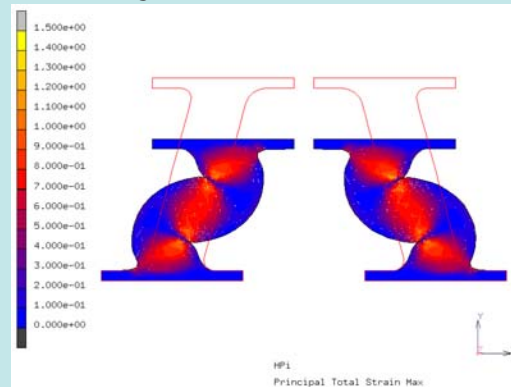

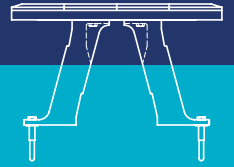

# PPI TYPE

PPI type is an improved version of the Pi type. It features a size range of 400H to 1250H, and is capable of providing the optimum system to meet a wide variety of needs.

## Performance

The unique and compact profile of the PPI type achieves improved design deflection of 57.5%. With an improved absorption energy of 12.7% in comparison with the HPI model, this product allows for system design with improved cost effectiveness.

## Minimal Fixing bolt

Thanks to a re-configuration of the fixing bolt as a result of re-engineering efforts, this product requires fewer fixing bolts than Pi type.

## Various System Variations

The rubber legs can be mounted horizontally or vertically in relation to the steel frame, allowing the user to configure the system freely. In addition, the height, length, and combination of rubber compounds can be selected freely, and the height can be adjusted, so as to achieve the ideal E/R ratio. (E/R ratio: Energy/reaction force ratio) It is applicable to combine plastic pad and rubber leg without steel panel for the buffer up to 1000 H size.

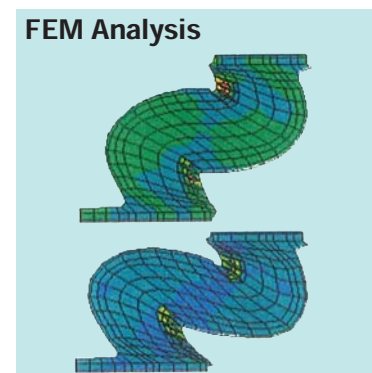
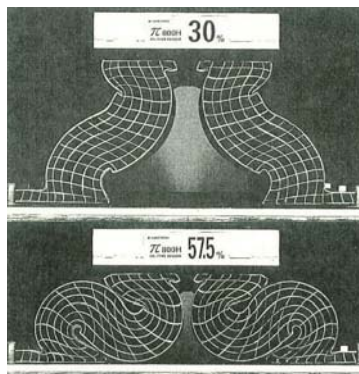
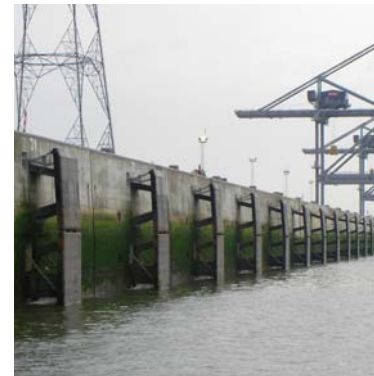





Size & Dimension

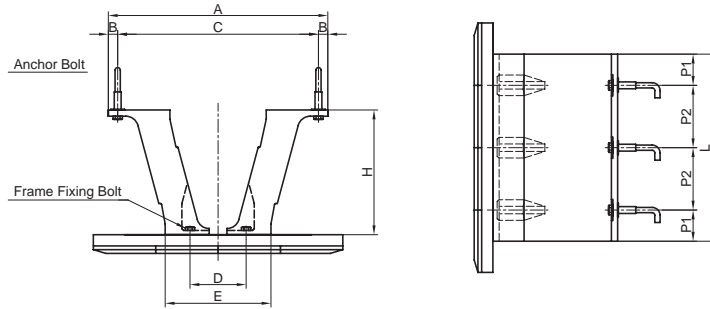

	H [mm]	L [mm]	A [mm]	B [mm]	C [mm]	D [mm]	E [mm]	P1 [mm]	P2 [mm]	Anchor Bolt Size & Qty	Fixing Bolt Size & Qty	Weight [kgf]
PPI-400H	400	1,000	830	60	710	186	360	250	500	M30×4	M24×4	165
PPI-400H	400	1,500	830	60	710	186	360	250	500×2	M30×6	M24×6	250
PPI-400H	400	2,000	830	60	710	186	360	250	500×3	M30×8	M24×8	380
PPI-500H	500	1,000	970	60	850	230	430	250	500	M30×4	M30×4	260
PPI-500H	500	1,500	970	60	850	230	430	250	500×2	M30×6	M30×6	400
PPI-500H	500	2,000	970	60	850	230	430	250	500×3	M30×8	M30×8	540
PPI-600H	600	1,000	1,140	65	1,010	276	520	250	500	M36×4	M30×4	360
PPI-600H	600	1,500	1,140	65	1,010	276	520	250	500×2	M36×6	M30×6	540
PPI-600H	600	2,000	1,140	65	1,010	276	520	250	500×3	M36×8	M30×8	720
PPI-800H	800	1,000	1,450	70	1,310	362	680	250	500	M36×4	M36×4	575
PPI-800H	800	1,500	1,450	70	1,310	362	680	250	500×2	M36×6	M36×6	865
PPI-800H	800	2,000	1,450	70	1,310	362	680	250	500×3	M36×8	M36×8	1,220
PPI-1000H	1,000	1,000	1,760	75	1,610	450	850	250	500	M42×4	M42×4	905
PPI-1000H	1,000	1,500	1,760	75	1,610	450	850	250	500×2	M42×6	M42×6	1,380
PPI-1000H	1,000	2,000	1,760	75	1,610	450	850	250	500×3	M42×8	M42×8	1,840
PPI-1150H	1,150	1,000	1,960	75	1,810	525	990	250	500	M42×4	M42×4	1,180
PPI-1150H	1,150	1,500	1,960	75	1,810	525	990	250	500×2	M42×6	M42×6	1,645
PPI-1150H	1,150	2,000	1,960	75	1,810	525	990	250	500×3	M42×8	M42×8	2,300
PPI-1250H	1,250	1,000	2,120	75	1,970	570	1,070	250	500	M42×4	M42×4	1,320
PPI-1250H	1,250	1,500	2,120	75	1,970	570	1,070	250	500×2	M42×6	M42×6	1,980
PPI-1250H	1,250	2,000	2,120	75	1,970	570	1,070	250	500×3	M42×8	M42×8	2,640

※The data are subject to change without notice.

Performance Characteristics (1.0m Long, one pair of Fender)

The performance is in proportion to rubber leg length

Compound	CPS (1.55)		CP0 (1.40)		CP1 (1.20)		CP2 (1.00)		CP3 (0.80)											
	Deflection	57.5%	60%	57.5%	60%	57.5%	60%	57.5%	60%	57.5%	60%									
Height	R (kN)	E (kN-m)	R (kN)	E (kN-m)	R (kN)	E (kN-m)	R (kN)	E (kN-m)	R (kN)	E (kN-m)	R (kN)	E (kN-m)								
PPI-400H	321	58.4	365	61.8	290	52.7	330	55.8	249	45.2	283	47.9	207	37.7	235	39.9	166	30.1	189	31.9
PPI-500H	401	91.2	456	96.6	363	82.4	413	87.3	311	70.6	354	74.8	259	58.9	294	62.4	207	47.1	235	49.9
PPI-600H	482	131	548	139	435	119	495	126	373	102	424	108	311	84.8	354	89.8	249	67.8	283	71.8
PPI-800H	642	234	730	247	580	211	659	223	497	181	565	192	414	151	471	160	331	121	376	128
PPI-1000H	803	365	913	387	725	330	824	349	622	283	707	299	518	235	589	249	414	188	471	200
PPI-1150H	923	483	1049	511	834	436	948	462	715	374	813	396	596	311	678	329	477	249	542	264
PPI-1250H	1004	570	1142	604	906	515	1030	545	777	441	883	467	647	368	736	390	518	294	589	311

R:Reaction Load E:Energy Absorption

57.5%:Rated Deflection 60.0%:Maximum Deflection

Tolerance:-10% for min. Energy Absorption and +10% for max Reaction Load

※Special rubber compound can be available depending on design conditions. The range of rubber compound is CP4-CPX. Please contact us for further detail.

※The data are subject to change without notice.

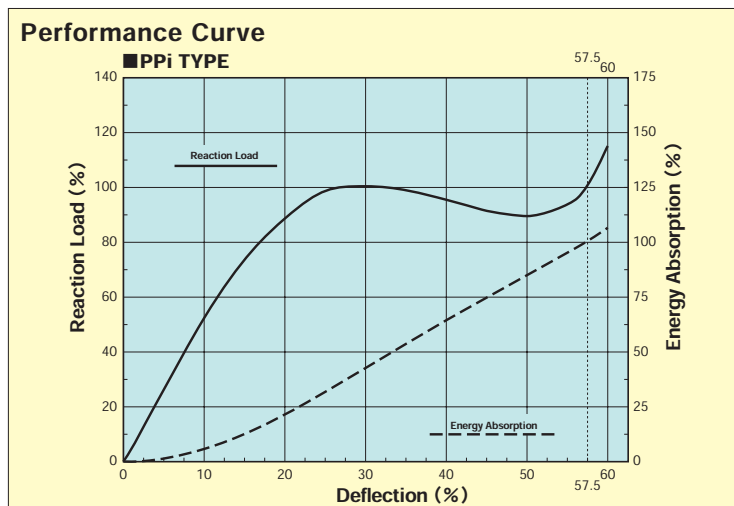

# Lambda TYPE



Since LMD inception in 1979 to be a more superior V fender than the Hyper Ace (V), it has won the hearts of many end users and remains the top seller in the global market for V shape fenders.

## Performance

The unique profile of the Lambda was developed using FEM (finite element method) technology which was the most advanced technology available at the time of its design, and it achieves an improved design deflection to 52.5%, compared to 45% of the Hyper Ace fender. Performance is enhanced by 26% in greater energy absorption as compared to conventional V-shape fender of the same size and the same rubber compound at a certain level of reaction load. Selection of smaller size fenders in comparison to the Hyper Ace Fender can be realized with this improved performance. LMD model, during deflection, maintains its shape and contact area allowing an even distribution of surface pressure to the ship's hull.

## LMD.F type

LMD.F type features a steel plate with nuts embedded in the contact part of the fender, and a steel frame can be mounted or polyethylene padsheet bolted to fenders of this type.



## LMD.S type

Lambda type allows molecular bonded UHMW-PE Facing without any fastener. The UHMW-PE plastic pad surface ensure low friction contact to the ships and not smear its colour onto ship's hull. Also LMD.S TYPE has same compression performance of Lambda (LMD) TYPE FENDER. Maximum Nominal Length: 2,000mm

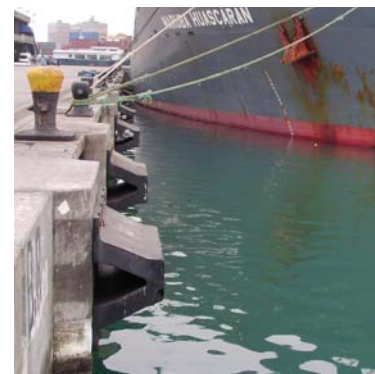



Size & Dimension

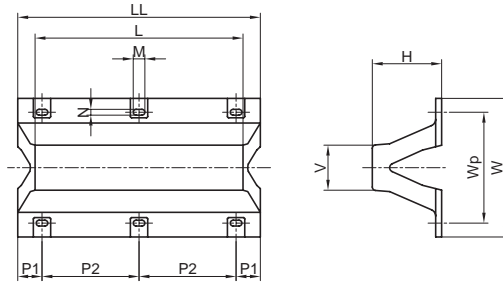

	H [mm]	L [mm]	LL [mm]	W [mm]	Wp [mm]	V [mm]	M [mm]	N [mm]	P1 [mm]	P2 [mm]	Anchor Bolt Size & Qty	Weight [kg]
LMD-250H	250	1,000	1,125	500	400	162	58	29	112.5	900	M24×4	75
LMD-250H	250	1,500	1,625	500	400	162	58	29	112.5	700×2	M24×6	108
LMD-250H	250	2,000	2,125	500	400	162	58	29	117.5	630×3	M24×8	155
LMD-250H	250	2,500	2,625	500	400	162	58	29	112.5	800×3	M24×8	190
LMD-250H	250	3,000	3,125	500	400	162	58	29	112.5	725×4	M24×10	225
LMD-250H	250	3,500	3,625	500	400	162	58	29	112.5	850×4	M24×10	260
LMD-250H	250	4,000	4,125	500	400	162	58	29	112.5	780×5	M24×12	300
LMD-300H	300	1,000	1,150	600	480	195	70	35	125	900	M30×4	105
LMD-300H	300	1,500	1,650	600	480	195	70	35	125	700×2	M30×6	150
LMD-300H	300	2,000	2,150	600	480	195	70	35	130	630×3	M30×8	215
LMD-300H	300	2,500	2,650	600	480	195	70	35	125	800×3	M30×8	250
LMD-300H	300	3,000	3,150	600	480	195	70	35	125	725×4	M30×10	300
LMD-300H	300	3,500	3,650	600	480	195	70	35	125	850×4	M30×10	350
LMD-350H	350	1,000	1,175	700	560	228	70	35	137.5	900	M30×4	145
LMD-350H	350	1,500	1,675	700	560	228	70	35	137.5	700×2	M30×6	220
LMD-350H	350	2,000	2,175	700	560	228	70	35	142.5	630×3	M30×8	285
LMD-350H	350	2,500	2,675	700	560	228	70	35	137.5	800×3	M30×8	360
LMD-400H	400	1,000	1,200	800	640	260	84	42	150	900	M36×4	200
LMD-400H	400	1,500	1,700	800	640	260	84	42	150	700×2	M36×6	280
LMD-400H	400	2,000	2,200	800	640	260	84	42	155	630×3	M36×8	395
LMD-400H	400	2,500	2,700	800	640	260	84	42	150	800×3	M36×8	460
LMD-400H	400	3,000	3,200	800	640	260	84	42	150	725×4	M36×10	540
LMD-400H	400	3,500	3,700	800	640	260	84	42	150	850×4	M36×10	665
LMD-500H	500	1,000	1,250	1,000	800	325	84	42	175	900	M36×4	320
LMD-500H	500	1,500	1,750	1,000	800	325	84	42	175	700×2	M36×6	435
LMD-500H	500	2,000	2,250	1,000	800	325	84	42	180	630×3	M36×8	570
LMD-500H	500	2,500	2,750	1,000	800	325	84	42	175	800×3	M36×8	715
LMD-500H	500	3,000	3,250	1,000	800	325	84	42	175	725×4	M36×10	855
LMD-500H	500	3,500	3,750	1,000	800	325	84	42	175	850×4	M36×10	960
LMD-600H	600	1,000	1,300	1,200	960	390	98	49	200	900	M42×4	415
LMD-600H	600	1,500	1,800	1,200	960	390	98	49	200	700×2	M42×6	624
LMD-600H	600	2,000	2,300	1,200	960	390	98	49	205	630×3	M42×8	835
LMD-600H	600	2,500	2,800	1,200	960	390	98	49	200	800×3	M42×8	1,030
LMD-600H	600	3,000	3,300	1,200	960	390	98	49	200	725×4	M42×10	1,195
LMD-600H	600	3,500	3,800	1,200	960	390	98	49	200	850×4	M42×10	1,450
LMD-600H	600	4,000	4,300	1,200	960	390	98	49	200	780×5	M42×12	1,640
LMD-800H	800	1,000	1,400	1,500	1,300	520	110	55	250	900	M48×4	820
LMD-800H	800	1,500	1,900	1,500	1,300	520	110	55	250	700×2	M48×6	1,130
LMD-800H	800	2,000	2,400	1,500	1,300	520	110	55	255	630×3	M48×8	1,470
LMD-800H	800	2,500	2,900	1,500	1,300	520	110	55	250	800×3	M48×8	1,780
LMD-800H	800	3,000	3,400	1,500	1,300	520	110	55	250	725×4	M48×10	2,275
LMD-800H	800	3,500	3,900	1,500	1,300	520	110	55	250	850×4	M48×10	3,030
LMD-1000H	1,000	1,000	1,500	1,800	1,550	650	110	55	300	900	M48×4	1,235
LMD-1000H	1,000	1,500	2,000	1,800	1,550	650	110	55	300	700×2	M48×6	1,780
LMD-1000H	1,000	2,000	2,500	1,800	1,550	650	110	55	305	630×3	M48×8	2,305
LMD-1000H	1,000	2,500	3,000	1,800	1,550	650	110	55	300	800×3	M48×8	2,750
LMD-1000H	1,000	3,000	3,500	1,800	1,550	650	110	55	300	725×4	M48×10	3,240

※Space of bolt (P1,P2) can be changed.  
 ※The data are subject to change without notice.  
 ※Smaller bolt size can be proposed depending on the design condition.



### Performance Characteristics (1.0m Long Fender)

The performance is in proportion to rubber leg length

Compound	CLS (1.55)				CL0 (1.40)				CL1 (1.20)				CL2 (1.00)				CL3 (0.80)			
	52.5%		55%		52.5%		55%		52.5%		55%		52.5%		55%		52.5%		55%	
Fender Height	R (kN)	E (kN-m)	R (kN)	E (kN-m)	R (kN)	E (kN-m)	R (kN)	E (kN-m)	R (kN)	E (kN-m)	R (kN)	E (kN-m)	R (kN)	E (kN-m)	R (kN)	E (kN-m)	R (kN)	E (kN-m)	R (kN)	E (kN-m)
LMD-250H	238	24.9	261	26.4	215	22.5	235	23.9	184	19.3	201	20.5	153	16.1	168	17.1	123	12.9	135	13.7
LMD-300H	285	35.9	312	38.1	258	32.4	283	34.4	221	27.8	242	29.5	184	23.2	201	24.6	147	18.5	161	19.6
LMD-350H	333	48.9	365	51.9	300	44.2	329	46.9	258	37.9	283	40.2	215	31.5	235	33.5	172	25.2	188	26.8
LMD-400H	380	63.9	416	67.9	343	57.7	376	61.3	294	49.4	322	52.5	245	41.2	268	43.8	196	33	215	35
LMD-500H	475	100	520	106	429	90.1	470	95.7	368	77.3	403	82.1	307	64.4	336	68.4	245	51.5	268	54.7
LMD-600H	570	144	624	153	515	130	564	138	441	111	483	118	368	92.7	403	98.4	294	74.2	322	78.8
LMD-800H	760	255	832	271	687	231	752	245	589	198	645	210	491	165	538	175	392	132	429	140
LMD-1000H	950	399	1040	424	858	361	940	383	736	309	806	328	613	258	671	274	491	206	538	219

R: Reaction Load E: Energy Absorption  
 52.5%: Rated Deflection 55.0%: Maximum Deflection  
 Tolerance: -10% for min. Energy Absorption and +10% for max Reaction Load  
 ※Special rubber compound can be available depending on design conditions. The range of rubber compound is CL4-CLX. Please contact us for further detail.  
 ※The data are subject to change without notice.

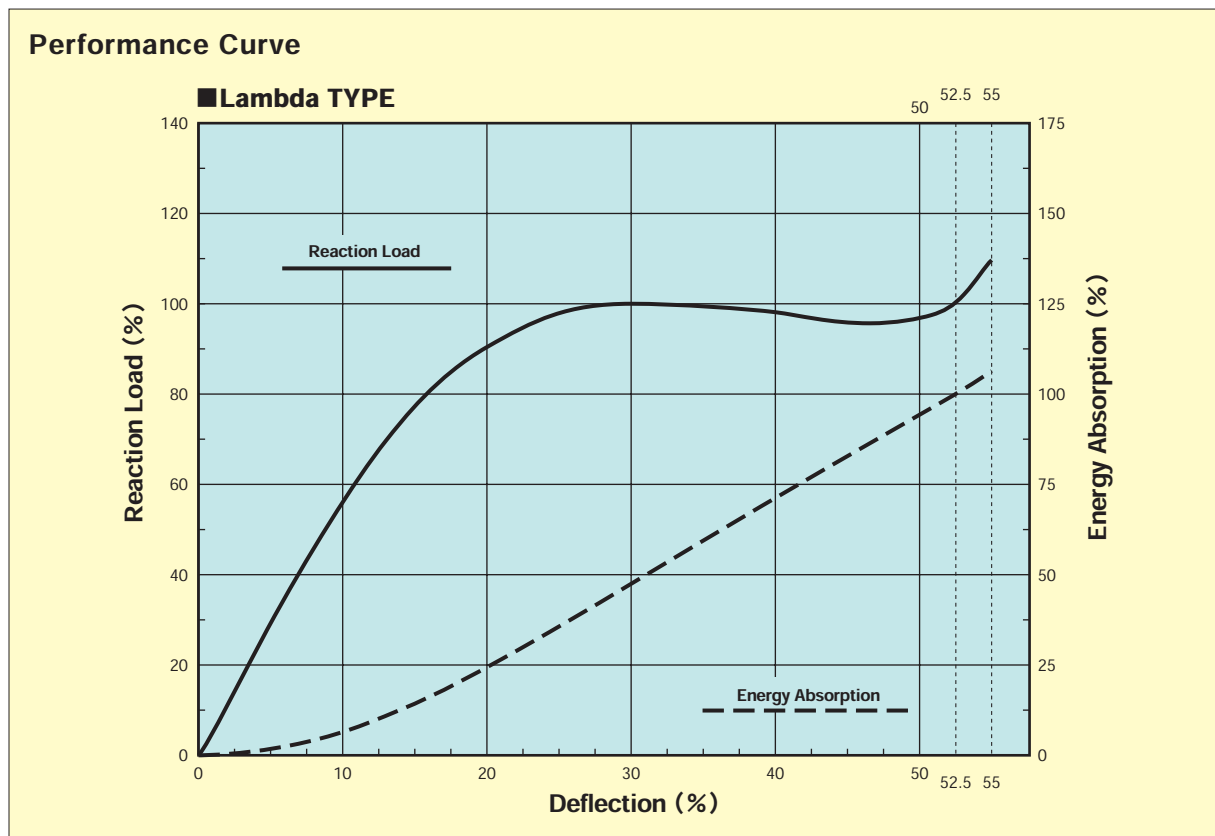



Size & Dimension

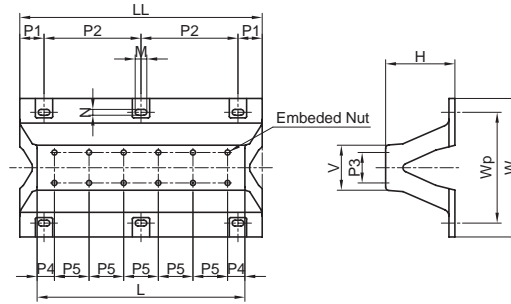

	H [mm]	L [mm]	LL [mm]	W [mm]	WP [mm]	V [mm]	M [mm]	N [mm]	P1 [mm]	P2 [mm]	P3 [mm]	P4 [mm]	P5 [mm]	Anchor Bolt Size & Qty	Fixing Bolt Size & Qty	Weight [kgf]
LMD.F-250H	250	1,000	1,125	500	400	162	58	29	112.5	900	80	150	350×2	M24×4	M20×6	84
LMD.F-250H	250	1,500	1,625	500	400	162	58	29	112.5	700×2	80	150	400×3	M24×6	M20×8	121
LMD.F-250H	250	2,000	2,125	500	400	162	58	29	117.5	630×3	80	150	425×4	M24×8	M20×10	173
LMD.F-250H	250	2,500	2,625	500	400	162	58	29	112.5	800×3	80	150	440×5	M24×8	M20×12	212
LMD.F-250H	250	3,000	3,125	500	400	162	58	29	112.5	725×4	80	150	450×6	M24×10	M20×14	252
LMD.F-250H	250	3,500	3,625	500	400	162	58	29	112.5	850×4	80	157.5	455×7	M24×10	M20×16	291
LMD.F-250H	250	4,000	4,125	500	400	162	58	29	112.5	780×5	80	160	460×8	M24×12	M20×18	336
LMD.F-300H	300	1,000	1,150	600	480	195	70	35	125	900	100	150	350×2	M30×4	M20×6	119
LMD.F-300H	300	1,500	1,650	600	480	195	70	35	125	700×2	100	150	400×3	M30×6	M20×8	175
LMD.F-300H	300	2,000	2,150	600	480	195	70	35	130	630×3	100	150	425×4	M30×8	M20×10	243
LMD.F-300H	300	2,500	2,650	600	480	195	70	35	125	800×3	100	150	440×5	M30×8	M20×12	286
LMD.F-300H	300	3,000	3,150	600	480	195	70	35	125	725×4	100	150	450×6	M30×10	M20×14	343
LMD.F-300H	300	3,500	3,650	600	480	195	70	35	125	850×4	100	157.5	455×7	M30×10	M20×16	400
LMD.F-350H	350	1,000	1,175	700	560	228	70	35	137.5	900	130	150	350×2	M30×4	M24×6	162
LMD.F-350H	350	1,500	1,675	700	560	228	70	35	137.5	700×2	130	150	400×3	M30×6	M24×8	246
LMD.F-350H	350	2,000	2,175	700	560	228	70	35	142.5	630×3	130	150	425×4	M30×8	M24×10	320
LMD.F-350H	350	2,500	2,675	700	560	228	70	35	137.5	800×3	130	150	440×5	M30×8	M24×12	404
LMD.F-400H	400	1,000	1,200	800	640	260	84	42	150	900	155	150	350×2	M36×4	M24×6	265
LMD.F-400H	400	1,500	1,700	800	640	260	84	42	150	700×2	155	150	400×3	M36×6	M24×8	379
LMD.F-400H	400	2,000	2,200	800	640	260	84	42	155	630×3	155	150	425×4	M36×8	M24×10	527
LMD.F-400H	400	2,500	2,700	800	640	260	84	42	150	800×3	155	150	440×5	M36×8	M24×12	626
LMD.F-400H	400	3,000	3,200	800	640	260	84	42	150	725×4	155	150	450×6	M36×10	M24×14	740
LMD.F-400H	400	3,500	3,700	800	640	260	84	42	150	850×4	155	157.5	455×7	M36×10	M24×16	899
LMD.F-500H	500	1,000	1,250	1,000	800	325	84	42	175	900	195	150	350×2	M36×4	M27×6	417
LMD.F-500H	500	1,500	1,750	1,000	800	325	84	42	175	700×2	195	150	400×3	M36×6	M27×8	582
LMD.F-500H	500	2,000	2,250	1,000	800	325	84	42	180	630×3	195	150	425×4	M36×8	M27×10	768
LMD.F-500H	500	2,500	2,750	1,000	800	325	84	42	175	800×3	195	150	440×5	M36×8	M27×12	963
LMD.F-500H	500	3,000	3,250	1,000	800	325	84	42	175	725×4	195	150	450×6	M36×10	M27×14	1,154
LMD.F-500H	500	3,500	3,750	1,000	800	325	84	42	175	850×4	195	157.5	455×7	M36×10	M27×16	1,309
LMD.F-600H	600	1,000	1,300	1,200	960	390	98	49	200	900	235	150	350×2	M42×4	M30×6	550
LMD.F-600H	600	1,500	1,800	1,200	960	390	98	49	200	700×2	235	150	400×3	M42×6	M30×8	829
LMD.F-600H	600	2,000	2,300	1,200	960	390	98	49	205	630×3	235	150	425×4	M42×8	M30×10	1,110
LMD.F-600H	600	2,500	2,800	1,200	960	390	98	49	200	800×3	235	150	440×5	M42×8	M30×12	1,375
LMD.F-600H	600	3,000	3,300	1,200	960	390	98	49	200	725×4	235	150	450×6	M42×10	M30×14	1,610
LMD.F-600H	600	3,500	3,800	1,200	960	390	98	49	200	850×4	235	157.5	455×7	M42×10	M30×16	1,935
LMD.F-600H	600	4,000	4,300	1,200	960	390	98	49	200	780×5	235	160	460×8	M42×12	M30×18	2,195
LMD.F-800H	800	1,000	1,400	1,500	1,300	520	110	55	250	900	310	150	350×2	M48×4	M33×6	1,026
LMD.F-800H	800	1,500	1,900	1,500	1,300	520	110	55	250	700×2	310	150	400×3	M48×6	M33×8	1,443
LMD.F-800H	800	2,000	2,400	1,500	1,300	520	110	55	255	630×3	310	150	425×4	M48×8	M33×10	1,890
LMD.F-800H	800	2,500	2,900	1,500	1,300	520	110	55	250	800×3	310	150	440×5	M48×8	M33×12	2,307
LMD.F-800H	800	3,000	3,400	1,500	1,300	520	110	55	250	725×4	310	150	450×6	M48×10	M33×14	2,909
LMD.F-800H	800	3,500	3,900	1,500	1,300	520	110	55	250	850×4	310	157.5	455×7	M48×10	M33×16	3,771
LMD.F-1000H	1,000	1,000	1,500	1,800	1,550	650	110	55	300	900	390	150	350×2	M48×4	M36×6	1,508
LMD.F-1000H	1,000	1,500	2,000	1,800	1,550	650	110	55	300	700×2	390	150	400×3	M48×6	M36×8	2,194
LMD.F-1000H	1,000	2,000	2,500	1,800	1,550	650	110	55	305	630×3	390	150	425×4	M48×8	M36×10	2,861
LMD.F-1000H	1,000	2,500	3,000	1,800	1,550	650	110	55	300	800×3	390	150	440×5	M48×8	M36×12	3,448
LMD.F-1000H	1,000	3,000	3,500	1,800	1,550	650	110	55	300	725×4	390	150	450×6	M48×10	M36×14	4,080

※Space of bolt (P1-P5) can be changed.  
 ※The data are subject to change without notice.  
 ※Smaller bolt size can be proposed depending on the design condition.



**Performance Characteristics (1.0m Long Fender)**

The performance is in proportion to rubber leg length

Compound	CLS(1.55)				CL0(1.40)				CL1(1.20)				CL2(1.00)				CL3(0.80)			
	50%		52.5%		50%		52.5%		50%		52.5%		50%		52.5%		50%		52.5%	
Deflection	R (kN)	E (kN-m)	R (kN)	E (kN-m)	R (kN)	E (kN-m)	R (kN)	E (kN-m)	R (kN)	E (kN-m)	R (kN)	E (kN-m)	R (kN)	E (kN-m)	R (kN)	E (kN-m)	R (kN)	E (kN-m)	R (kN)	E (kN-m)
LMD.F-250H	238	23.8	257	25.3	215	21.5	232	22.9	184	18.4	199	19.6	153	15.3	165	16.3	123	12.3	133	13.1
LMD.F-300H	285	34.2	308	36.4	258	30.9	279	32.9	221	26.5	239	28.2	184	22.1	199	23.5	147	17.7	159	18.9
LMD.F-350H	333	46.6	360	49.6	300	42.1	324	44.8	258	36.1	279	38.4	215	30	232	32	172	24	186	25.6
LMD.F-400H	380	60.8	410	64.8	343	54.9	370	58.5	294	47.1	318	50.2	245	39.2	265	41.7	196	31.4	212	33.4
LMD.F-500H	475	95	513	101	429	85.8	463	91.4	368	73.6	397	78.4	307	61.3	332	65.3	245	49.1	265	52.3
LMD.F-600H	570	137	616	146	515	124	556	132	441	106	476	113	368	88.3	397	94	294	70.6	318	75.2
LMD.F-800H	760	243	821	259	687	220	742	243	589	188	636	200	491	157	530	167	392	126	423	134
LMD.F-1000H	950	380	1026	405	858	343	927	366	736	294	795	313	613	245	662	261	491	196	530	209

R:Reaction Load E:Energy Absorption  
 50.0%:Rated Deflection 52.5%:Maximum Deflection  
 Tolerance:-10% for min. Energy Absorption and +10% for max Reaction Load  
 ※Special rubber compound can be available depending on design conditions. The range of rubber compound is CL4-CLX. Please contact us for further detail.  
 ※The data are subject to change without notice.

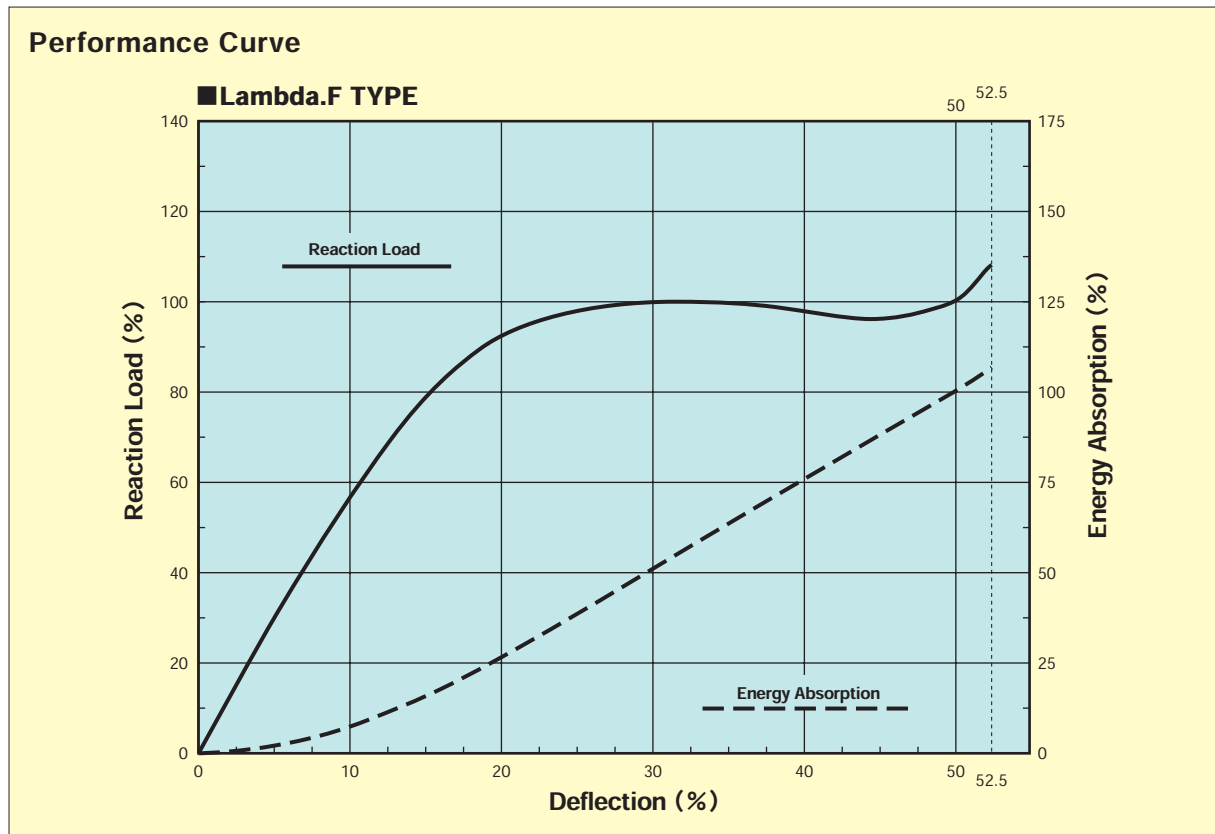



Compression

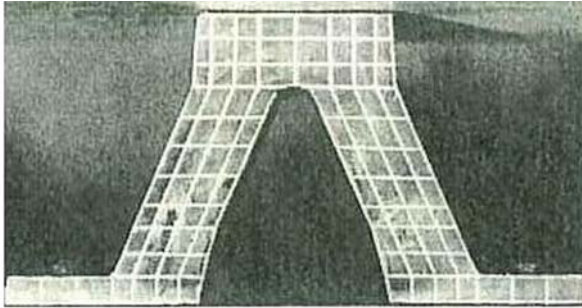

0%

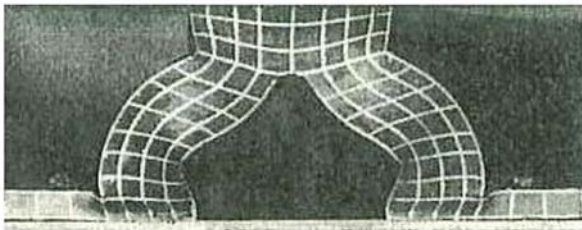

30%

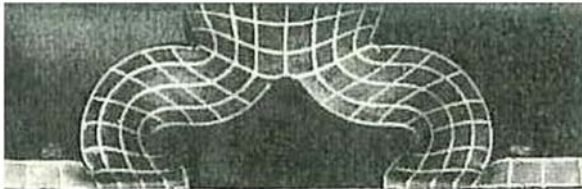

40%

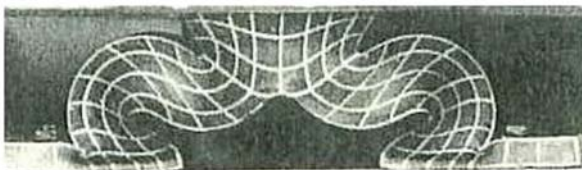

52.5%



30%



52.5%

FEM Analysis

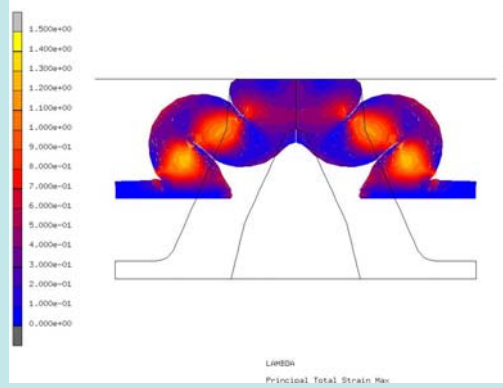
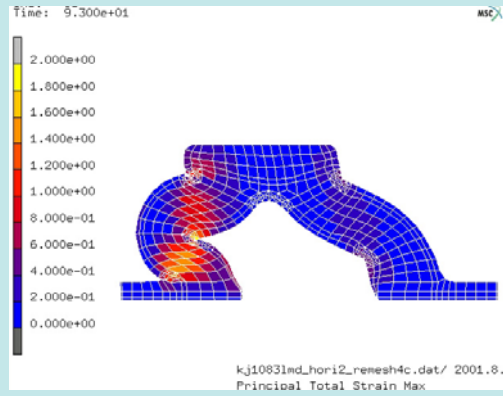

# Beta TYPE



Developed as an improved version of Lambda type, Beta type has been manufactured and sold since 1985.

## Performance

The unique profile, developed using FEM (finite element method) technology, achieves design deflection of 52.5%. With a wider area of contact face with a berthing ship, the face pressure is reduced and impact on the ship is minimized.

## Beta.F type

Beta.F type features a steel plate with nuts embedded in the contact part of the fender, and a steel frame can be mounted or polyethylene pad bolted to fenders of this type.

## Beta.S type

Beta type allows molecular bonded UHMW-PE Facing without any fastener. Also Beta.S TYPE has same compression performance of Beta TYPE FENDER. Maximum Nominal Length: 2,000mm

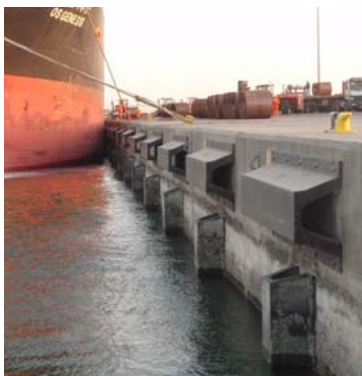
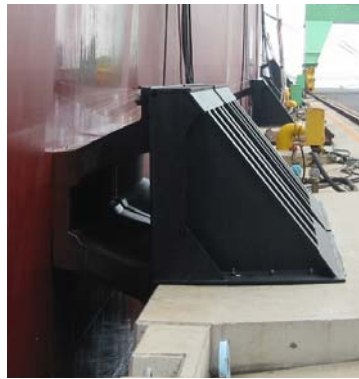





Size & Dimension

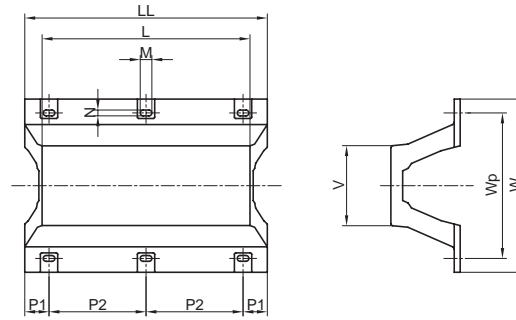

	H [mm]	L [mm]	LL [mm]	W [mm]	Wp [mm]	V [mm]	M [mm]	N [mm]	P1 [mm]	P2 [mm]	Anchor Bolt Size & Qty	Weight [kg]
Beta-250H	250	1,000	1,125	625	525	287.5	58	29	112.5	900	M24×4	90
Beta-250H	250	1,500	1,625	625	525	287.5	58	29	112.5	700×2	M24×6	140
Beta-250H	250	2,000	2,125	625	525	287.5	58	29	117.5	630×3	M24×8	170
Beta-250H	250	2,500	2,625	625	525	287.5	58	29	112.5	800×3	M24×8	220
Beta-250H	250	3,000	3,125	625	525	287.5	58	29	112.5	725×4	M24×10	260
Beta-250H	250	3,500	3,625	625	525	287.5	58	29	112.5	850×4	M24×10	300
Beta-300H	300	1,000	1,150	750	630	345	70	35	125	900	M30×4	120
Beta-300H	300	1,500	1,650	750	630	345	70	35	125	700×2	M30×6	190
Beta-300H	300	2,000	2,150	750	630	345	70	35	130	630×3	M30×8	230
Beta-300H	300	2,500	2,650	750	630	345	70	35	125	800×3	M30×8	300
Beta-300H	300	3,000	3,150	750	630	345	70	35	125	725×4	M30×10	390
Beta-300H	300	3,500	3,650	750	630	345	70	35	125	850×4	M30×10	450
Beta-400H	400	1,000	1,200	1,000	840	460	84	42	150	900	M36×4	208
Beta-400H	400	1,500	1,700	1,000	840	460	84	42	150	700×2	M36×6	305
Beta-400H	400	2,000	2,200	1,000	840	460	84	42	155	630×3	M36×8	430
Beta-400H	400	2,500	2,700	1,000	840	460	84	42	150	800×3	M36×8	590
Beta-400H	400	3,000	3,200	1,000	840	460	84	42	150	725×4	M36×10	720
Beta-400H	400	3,500	3,700	1,000	840	460	84	42	150	850×4	M36×10	850
Beta-500H	500	1,000	1,250	1,250	1,050	575	84	42	175	900	M36×4	350
Beta-500H	500	1,500	1,750	1,250	1,050	575	84	42	175	700×2	M36×6	485
Beta-500H	500	2,000	2,250	1,250	1,050	575	84	42	180	630×3	M36×8	630
Beta-500H	500	2,500	2,750	1,250	1,050	575	84	42	175	800×3	M36×8	790
Beta-500H	500	3,000	3,250	1,250	1,050	575	84	42	175	725×4	M36×10	950
Beta-500H	500	3,500	3,750	1,250	1,050	575	84	42	175	850×4	M36×10	1,105
Beta-500H	500	4,000	4,250	1,250	1,050	575	84	42	175	780×5	M36×12	1,270
Beta-500H	500	4,500	4,750	1,250	1,050	575	84	42	175	880×5	M36×12	1,440
Beta-600H	600	1,000	1,300	1,500	1,260	690	98	49	200	900	M42×4	560
Beta-600H	600	1,500	1,800	1,500	1,260	690	98	49	200	700×2	M42×6	730
Beta-600H	600	2,000	2,300	1,500	1,260	690	98	49	205	630×3	M42×8	1,020
Beta-600H	600	2,500	2,800	1,500	1,260	690	98	49	200	800×3	M42×8	1,250
Beta-600H	600	3,000	3,300	1,500	1,260	690	98	49	200	725×4	M42×10	1,500
Beta-600H	600	3,500	3,800	1,500	1,260	690	98	49	200	850×4	M42×10	1,760
Beta-800H	800	1,000	1,400	1,900	1,700	920	110	55	250	900	M48×4	880
Beta-800H	800	1,500	1,900	1,900	1,700	920	110	55	250	700×2	M48×6	1,220
Beta-800H	800	2,000	2,400	1,900	1,700	920	110	55	255	630×3	M48×8	1,560
Beta-800H	800	2,500	2,900	1,900	1,700	920	110	55	250	800×3	M48×8	1,965
Beta-800H	800	3,000	3,400	1,900	1,700	920	110	55	250	725×4	M48×10	2,400
Beta-800H	800	3,500	3,900	1,900	1,700	920	110	55	250	850×4	M48×10	2,850
Beta-800H	800	4,000	4,400	1,900	1,700	920	110	55	250	780×5	M48×12	3,305
Beta-1000H	1,000	1,000	1,500	2,300	2,050	1,150	110	55	300	900	M48×4	1,560
Beta-1000H	1,000	1,500	2,000	2,300	2,050	1,150	110	55	300	700×2	M48×6	1,830
Beta-1000H	1,000	2,000	2,500	2,300	2,050	1,150	110	55	305	630×3	M48×8	2,335
Beta-1000H	1,000	2,500	3,000	2,300	2,050	1,150	110	55	300	800×3	M48×8	2,840
Beta-1000H	1,000	3,000	3,500	2,300	2,050	1,150	110	55	300	725×4	M48×10	3,540

※Space of bolt (P1,P2) can be changed.  
 ※The data are subject to change without notice.  
 ※Smaller bolt size can be proposed depending on the design condition.



### Performance Characteristics (1.0m Long Fender)

The performance is in proportion to rubber leg length

Compound	CBB (1.76)				CB0 (1.40)				CB1 (1.20)				CB2 (1.00)				CB3 (0.80)			
	52.5%		55%		52.5%		55%		52.5%		55%		52.5%		55%		52.5%		55%	
Height	R (kN)	E (kN-m)	R (kN)	E (kN-m)	R (kN)	E (kN-m)	R (kN)	E (kN-m)	R (kN)	E (kN-m)	R (kN)	E (kN-m)	R (kN)	E (kN-m)	R (kN)	E (kN-m)	R (kN)	E (kN-m)	R (kN)	E (kN-m)
BETA-200H	199	16.7	221	17.8	158	13.3	175	41.1	135	11.4	150	12.1	113	9.5	125	10.1	90	7.6	100	8.1
BETA-250H	248	26.1	275	27.7	197	20.8	219	22.1	169	17.8	188	18.9	141	14.8	157	15.7	113	11.9	125	12.6
BETA-300H	298	37.6	331	40	237	29.9	263	31.8	203	25.6	225	27.2	169	21.4	188	22.7	135	17.1	150	18.2
BETA-400H	397	66.9	441	71.1	316	53.2	351	56.6	271	45.6	301	48.5	226	38	251	40.4	181	30.4	201	32.3
BETA-500H	496	104	551	111	395	83.1	438	88.3	338	71.2	375	75.7	282	59.4	313	63.1	226	47.5	251	50.5
BETA-600H	596	150	662	159	474	120	526	128	406	103	451	109	338	85.5	375	90.9	271	68.4	301	72.7
BETA-800H	794	267	881	284	632	213	702	226	542	182	602	193	451	152	501	162	361	122	401	130
BETA-1000H	993	418	1102	444	790	332	877	353	677	285	751	303	564	237	626	252	451	190	501	202

R:Reaction Load E:Energy Absorption  
 52.5%:Rated Deflection 55.0%:Maximum Deflection  
 Tolerance:-10% for min. Energy Absorption and +10% for max Reaction Load  
 ※Special rubber compound can be available depending on design conditions. The range of rubber compound is CB4-CBX. Please contact us for further detail.  
 ※The data are subject to change without notice.

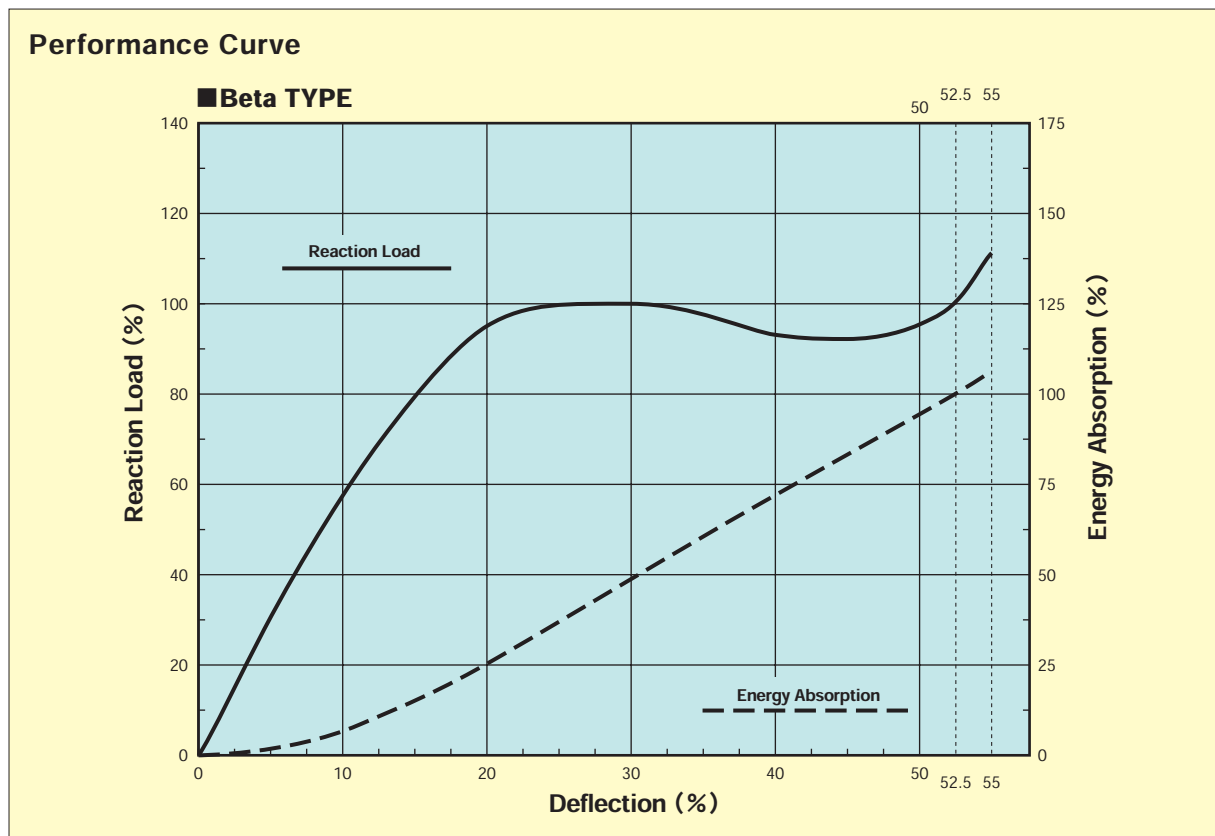



Size & Dimension

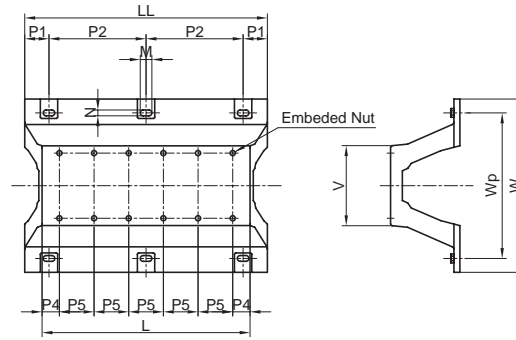

	H [mm]	L [mm]	LL [mm]	W [mm]	WP [mm]	V [mm]	M [mm]	N [mm]	P1 [mm]	P2 [mm]	P3 [mm]	P4 [mm]	P5 [mm]	Anchor Bolt Size & Qty	Fixing Bolt Size & Qty	Weight [kgf]
Beta.F-250H	250	1,000	1,125	625	525	287.5	58	29	112.5	900	190	150	350×2	M24×4	M20×6	106
Beta.F-250H	250	1,500	1,625	625	525	287.5	58	29	112.5	700×2	190	150	400×3	M24×6	M20×8	165
Beta.F-250H	250	2,000	2,125	625	525	287.5	58	29	117.5	630×3	190	150	425×4	M24×8	M20×10	203
Beta.F-250H	250	2,500	2,625	625	525	287.5	58	29	112.5	800×3	190	150	440×5	M24×8	M20×12	262
Beta.F-250H	250	3,000	3,125	625	525	287.5	58	29	112.5	725×4	190	150	450×6	M24×10	M20×14	310
Beta.F-250H	250	3,500	3,625	625	525	287.5	58	29	112.5	850×4	190	157.5	455×7	M24×10	M20×16	358
Beta.F-300H	300	1,000	1,150	750	630	345	70	35	125	900	245	150	350×2	M30×4	M20×6	146
Beta.F-300H	300	1,500	1,650	750	630	345	70	35	125	700×2	245	150	400×3	M30×6	M20×8	230
Beta.F-300H	300	2,000	2,150	750	630	345	70	35	130	630×3	245	150	425×4	M30×8	M20×10	283
Beta.F-300H	300	2,500	2,650	750	630	345	70	35	125	800×3	245	150	440×5	M30×8	M20×12	366
Beta.F-300H	300	3,000	3,150	750	630	345	70	35	125	725×4	245	150	450×6	M30×10	M20×14	470
Beta.F-300H	300	3,500	3,650	750	630	345	70	35	125	850×4	245	157.5	455×7	M30×10	M20×16	543
Beta.F-400H	400	1,000	1,200	1,000	840	460	84	42	150	900	350	150	350×2	M36×4	M24×6	242
Beta.F-400H	400	1,500	1,700	1,000	840	460	84	42	150	700×2	350	150	400×3	M36×6	M24×8	357
Beta.F-400H	400	2,000	2,200	1,000	840	460	84	42	155	630×3	350	150	425×4	M36×8	M24×10	500
Beta.F-400H	400	2,500	2,700	1,000	840	460	84	42	150	800×3	350	150	440×5	M36×8	M24×12	678
Beta.F-400H	400	3,000	3,200	1,000	840	460	84	42	150	725×4	350	150	450×6	M36×10	M24×14	826
Beta.F-400H	400	3,500	3,700	1,000	840	460	84	42	150	850×4	350	157.5	455×7	M36×10	M24×16	974
Beta.F-500H	500	1,000	1,250	1,250	1,050	575	84	42	175	900	440	150	350×2	M36×4	M27×6	408
Beta.F-500H	500	1,500	1,750	1,250	1,050	575	84	42	175	700×2	440	150	400×3	M36×6	M27×8	573
Beta.F-500H	500	2,000	2,250	1,250	1,050	575	84	42	180	630×3	440	150	425×4	M36×8	M27×10	748
Beta.F-500H	500	2,500	2,750	1,250	1,050	575	84	42	175	800×3	440	150	440×5	M36×8	M27×12	938
Beta.F-500H	500	3,000	3,250	1,250	1,050	575	84	42	175	725×4	440	150	450×6	M36×10	M27×14	1,128
Beta.F-500H	500	3,500	3,750	1,250	1,050	575	84	42	175	850×4	440	157.5	455×7	M36×10	M27×16	1,314
Beta.F-500H	500	4,000	4,250	1,250	1,050	575	84	42	175	780×5	440	160	460×8	M36×12	M27×18	1,509
Beta.F-500H	500	4,500	4,750	1,250	1,050	575	84	42	175	880×5	440	157.5	465×9	M36×12	M27×20	1,709
Beta.F-600H	600	1,000	1,300	1,500	1,260	690	98	49	200	900	525	150	350×2	M42×4	M30×6	642
Beta.F-600H	600	1,500	1,800	1,500	1,260	690	98	49	200	700×2	525	150	400×3	M42×6	M30×8	855
Beta.F-600H	600	2,000	2,300	1,500	1,260	690	98	49	205	630×3	525	150	425×4	M42×8	M30×10	1,188
Beta.F-600H	600	2,500	2,800	1,500	1,260	690	98	49	200	800×3	525	150	440×5	M42×8	M30×12	1,461
Beta.F-600H	600	3,000	3,300	1,500	1,260	690	98	49	200	725×4	525	150	450×6	M42×10	M30×14	1,754
Beta.F-600H	600	3,500	3,800	1,500	1,260	690	98	49	200	850×4	525	157.5	455×7	M42×10	M30×16	2,057
Beta.F-800H	800	1,000	1,400	1,900	1,700	920	110	55	250	900	700	150	350×2	M48×4	M33×6	1,006
Beta.F-800H	800	1,500	1,900	1,900	1,700	920	110	55	250	700×2	700	150	400×3	M48×6	M33×8	1,411
Beta.F-800H	800	2,000	2,400	1,900	1,700	920	110	55	255	630×3	700	150	425×4	M48×8	M33×10	1,817
Beta.F-800H	800	2,500	2,900	1,900	1,700	920	110	55	250	800×3	700	150	440×5	M48×8	M33×12	2,288
Beta.F-800H	800	3,000	3,400	1,900	1,700	920	110	55	250	725×4	700	150	450×6	M48×10	M33×14	2,788
Beta.F-800H	800	3,500	3,900	1,900	1,700	920	110	55	250	850×4	700	157.5	455×7	M48×10	M33×16	3,304
Beta.F-800H	800	4,000	4,400	1,900	1,700	920	110	55	250	780×5	700	160	460×8	M48×12	M33×18	3,824
Beta.F-1000H	1,000	1,000	1,500	2,300	2,050	1,150	110	55	300	900	875	150	350×2	M48×4	M36×6	1,738
Beta.F-1000H	1,000	1,500	2,000	2,300	2,050	1,150	110	55	300	700×2	875	150	400×3	M48×6	M36×8	2,100
Beta.F-1000H	1,000	2,000	2,500	2,300	2,050	1,150	110	55	305	630×3	875	150	425×4	M48×8	M36×10	2,750
Beta.F-1000H	1,000	2,500	3,000	2,300	2,050	1,150	110	55	300	800×3	875	150	440×5	M48×8	M36×12	3,450
Beta.F-1000H	1,000	3,000	3,500	2,300	2,050	1,150	110	55	300	725×4	875	150	450×6	M48×10	M36×14	4,417

※Space of bolt (P1-P5) can be changed.  
 ※The data are subject to change without notice.  
 ※Smaller bolt size can be proposed depending on the design condition.



**Performance Characteristics (1.0m Long Fender)**

The performance is in proportion to rubber leg length

Compound	CBB (1.76)				CB0 (1.40)				CB1 (1.20)				CB2 (1.00)				CB3 (0.80)			
	50%		52.5%		50%		52.5%		50%		52.5%		50%		52.5%		50%		52.5%	
Height	R (kN)	E (kN-m)	R (kN)	E (kN-m)	R (kN)	E (kN-m)	R (kN)	E (kN-m)	R (kN)	E (kN-m)	R (kN)	E (kN-m)	R (kN)	E (kN-m)	R (kN)	E (kN-m)	R (kN)	E (kN-m)	R (kN)	E (kN-m)
BETA.F-250H	248	24.6	270	26.2	197	19.6	215	20.8	169	16.8	184	17.9	141	14	154	14.9	113	11.2	123	11.9
BETA.F-300H	298	35.4	325	37.7	237	28.2	258	30	203	24.2	221	25.8	169	20.1	184	21.4	135	16.1	147	17.1
BETA.F-400H	397	63	433	67.1	316	50.1	344	53.4	271	42.9	295	45.7	226	35.8	246	38.1	181	28.6	197	30.5
BETA.F-500H	496	98.4	541	104	395	78.3	431	83.4	338	67.1	368	71.5	282	55.9	307	59.5	226	44.7	246	47.6
BETA.F-600H	596	142	650	151	474	113	517	120	406	96.6	443	103	338	80.5	368	85.7	271	64.4	295	68.6
BETA.F-800H	794	252	866	268	632	200	689	213	542	172	591	183	451	143	492	152	361	115	393	122
BETA.F-1000H	993	394	1082	419	790	313	861	333	677	268	738	285	564	224	615	238	451	179	492	191

R:Reaction Load E:Energy Absorption  
 50.0%:Rated Deflection 52.5%:Maximum Deflection  
 Tolerance:-10% for min. Energy Absorption and +10% for max Reaction Load  
 ※Special rubber compound can be available depending on design conditions. The range of rubber compound is CB4-CBX. Please contact us for further detail.  
 ※The data are subject to change without notice.

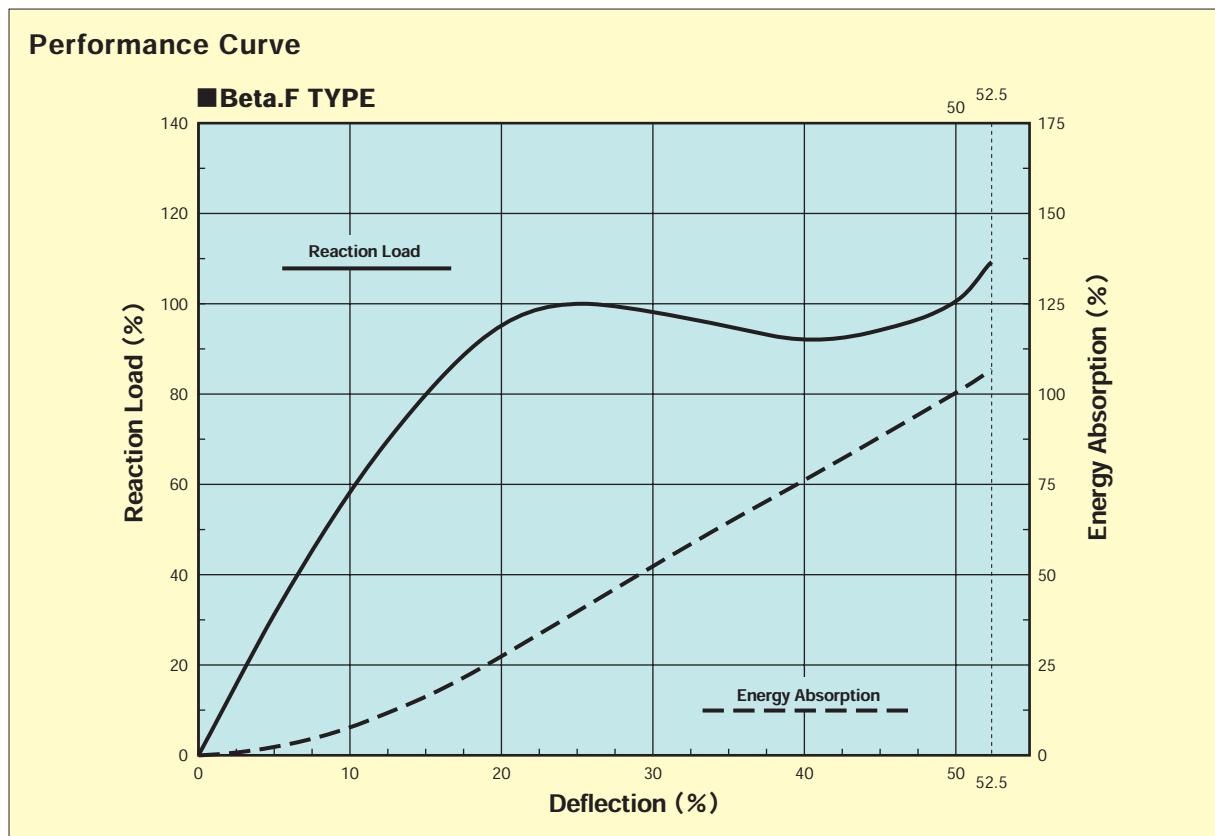



Compression

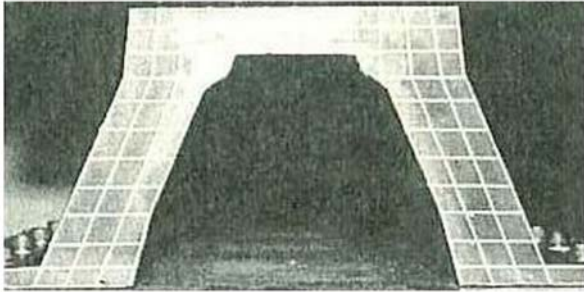

0%

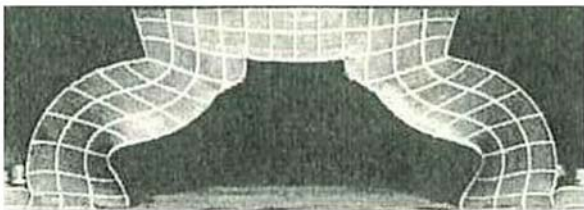

30%



40%



50%



52.5%

FEM Analysis

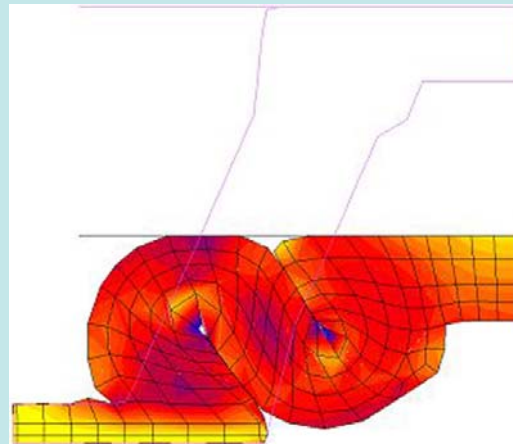

# Hyper Ace TYPE



The Hyper Ace was the first product to be manufactured and sold by Sumitomo Rubber Industries, beginning in 1967. Along with LMD type, it enjoys widespread popularity throughout the global marine fender market to this day.

## Performance

The Hyper Ace features a design deflection of 45.0%. The size range, from 150H to 1000H, makes this product capable of fulfilling a wide variety of demands.





Size & Dimension

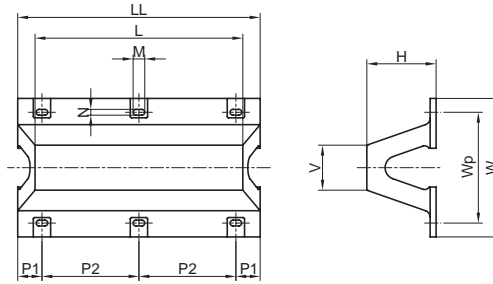

	H [mm]	L [mm]	LL [mm]	W [mm]	Wp [mm]	V [mm]	M [mm]	N [mm]	P1 [mm]	P2 [mm]	Anchor Bolt Size & Qty	Weight [kg]
HA-150H	150	1,000	1,075	300	240	98	50	25	92.5	900	M22×4	33
HA-150H	150	1,500	1,575	300	240	98	50	25	92.5	700×2	M22×6	50
HA-150H	150	2,000	2,075	300	240	98	50	25	92.5	630×3	M22×8	65
HA-150H	150	2,500	2,575	300	240	98	50	25	92.5	800×3	M22×8	80
HA-150H	150	3,000	3,075	300	240	98	50	25	92.5	725×4	M22×10	97
HA-150H	150	3,500	3,575	300	240	98	50	25	92.5	850×4	M22×10	113
HA-200H	200	1,000	1,100	400	320	130	58	29	100	900	M24×4	53
HA-200H	200	1,500	1,600	400	320	130	58	29	100	700×2	M24×6	80
HA-200H	200	2,000	2,100	400	320	130	58	29	105	630×3	M24×8	113
HA-200H	200	2,500	2,600	400	320	130	58	29	100	800×3	M24×8	143
HA-200H	200	3,000	3,100	400	320	130	58	29	100	725×4	M24×10	155
HA-200H	200	3,500	3,600	400	320	130	58	29	100	850×4	M24×10	180
HA-200H	200	4,000	4,100	400	320	130	58	29	100	780×5	M24×12	215
HA-250H	250	1,000	1,125	500	400	163	58	29	112.5	900	M24×4	78
HA-250H	250	1,500	1,625	500	400	163	58	29	112.5	700×2	M24×6	115
HA-250H	250	2,000	2,125	500	400	163	58	29	117.5	630×3	M24×8	162
HA-250H	250	2,500	2,625	500	400	163	58	29	112.5	800×3	M24×8	204
HA-250H	250	3,000	3,125	500	400	163	58	29	112.5	725×4	M24×10	227
HA-250H	250	3,500	3,625	500	400	163	58	29	112.5	850×4	M24×10	260
HA-250H	250	4,000	4,125	500	400	163	58	29	112.5	780×5	M24×12	305
HA-300H	300	1,000	1,150	600	480	195	70	35	125	900	M30×4	110
HA-300H	300	1,500	1,650	600	480	195	70	35	125	700×2	M30×6	161
HA-300H	300	2,000	2,150	600	480	195	70	35	130	630×3	M30×8	228
HA-300H	300	2,500	2,650	600	480	195	70	35	125	800×3	M30×8	283
HA-300H	300	3,000	3,150	600	480	195	70	35	125	725×4	M30×10	316
HA-300H	300	3,500	3,650	600	480	195	70	35	125	850×4	M30×10	364
HA-400H	400	1,000	1,200	800	640	260	84	42	150	900	M36×4	195
HA-400H	400	1,500	1,700	800	640	260	84	42	150	700×2	M36×6	280
HA-400H	400	2,000	2,200	800	640	260	84	42	155	630×3	M36×8	400
HA-400H	400	2,500	2,700	800	640	260	84	42	150	800×3	M36×8	495
HA-400H	400	3,000	3,200	800	640	260	84	42	150	725×4	M36×10	550
HA-400H	400	3,500	3,700	800	640	260	84	42	150	850×4	M36×10	640
HA-400H	400	4,000	4,200	800	640	260	84	42	150	780×5	M36×12	735
HA-400H	400	4,500	4,700	800	640	260	84	42	150	880×5	M36×12	840
HA-500H	500	1,000	1,250	1,000	800	325	84	42	175	900	M36×4	310
HA-500H	500	1,500	1,750	1,000	800	325	84	42	175	700×2	M36×6	455
HA-500H	500	2,000	2,250	1,000	800	325	84	42	180	630×3	M36×8	595
HA-500H	500	2,500	2,750	1,000	800	325	84	42	175	800×3	M36×8	740
HA-500H	500	3,000	3,250	1,000	800	325	84	42	175	725×4	M36×10	870
HA-500H	500	3,500	3,750	1,000	800	325	84	42	175	850×4	M36×10	1,025
HA-500H	500	4,000	4,250	1,000	800	325	84	42	175	780×5	M36×12	1,185
HA-600H	600	1,000	1,300	1,200	960	390	98	49	200	900	M42×4	450
HA-600H	600	1,500	1,800	1,200	960	390	98	49	200	700×2	M42×6	655
HA-600H	600	2,000	2,300	1,200	960	390	98	49	205	630×3	M42×8	875
HA-600H	600	2,500	2,800	1,200	960	390	98	49	200	800×3	M42×8	1,080
HA-600H	600	3,000	3,300	1,200	960	390	98	49	200	725×4	M42×10	1,285
HA-800H	800	1,000	1,400	1,500	1,300	520	110	55	250	900	M48×4	750
HA-800H	800	1,500	1,900	1,500	1,300	520	110	55	250	700×2	M48×6	1,165
HA-800H	800	2,000	2,400	1,500	1,300	520	110	55	255	630×3	M48×8	1,475
HA-800H	800	2,500	2,900	1,500	1,300	520	110	55	250	800×3	M48×8	1,895
HA-800H	800	3,000	3,400	1,500	1,300	520	110	55	250	725×4	M48×10	2,140
HA-1000H	1,000	1,000	1,500	1,800	1,550	650	110	55	300	900	M48×4	1,150
HA-1000H	1,000	1,500	2,000	1,800	1,550	650	110	55	300	700×2	M48×6	1,830
HA-1000H	1,000	2,000	2,500	1,800	1,550	650	110	55	305	630×3	M48×8	2,260
HA-1000H	1,000	2,500	3,000	1,800	1,550	650	110	55	300	800×3	M48×8	2,785
HA-1000H	1,000	3,000	3,500	1,800	1,550	650	110	55	300	725×4	M48×10	3,400

※Space of bolt (P1-P2) can be changed.  
 ※The data are subject to change without notice.  
 ※Smaller bolt size can be proposed depending on the design condition.



**Performance Characteristics (1.0m Long Fender)**

The performance is in proportion to rubber leg length

Compound	CV0 (1.40)		CV1 (1.20)		CV2 (1.00)		CV3 (0.80)		CV4 (0.60)											
	45%		47.5%		45%		47.5%		45%		47.5%									
Deflection	R (kN)	E (kN-m)	R (kN)	E (kN-m)	R (kN)	E (kN-m)	R (kN)	E (kN-m)	R (kN)	E (kN-m)	R (kN)	E (kN-m)								
Height																				
HA-150H	155	7.7	178	8.36	132	6.62	152	7.16	110	5.52	127	5.97	88.3	4.41	102	4.77	66.2	3.3	76.1	3.58
HA-200H	206	13.7	237	14.8	177	11.8	204	12.8	147	9.81	169	10.6	118	7.9	136	8.49	88.3	5.89	102	6.37
HA-250H	258	21.5	297	23.2	221	18.4	254	19.9	184	15.3	212	16.5	147	12.3	169	13.3	110	9.2	127	9.95
HA-300H	309	30.9	355	33.4	265	26.5	305	28.6	221	22.1	254	23.9	177	17.7	204	19.1	132	13.2	152	14.3
HA-400H	412	54.9	474	59.3	353	47.1	406	50.9	294	39.2	338	42.4	235	31.4	270	33.9	177	23.5	204	25.4
HA-500H	515	85.8	592	92.7	441	73.6	507	79.6	368	61.3	423	66.3	294	49.1	338	53.1	221	36.8	254	39.8
HA-600H	618	124	711	134	530	106	610	114.6	441	88.3	507	95.5	353	70.6	406	76.3	265	53	305	57.3
HA-800H	824	220	948	238	706	188	812	203	589	157	677	170	471	126	542	136	353	94.2	406	102
HA-1000H	1030	343	1185	371	883	294	1015	318	736	245	846	265	589	196	677	212	441	147	507	159

R: Reaction Load E: Energy Absorption  
 45.0%: Rated Deflection 47.5%: Maximum Deflection  
 Tolerance: -10% for min. Energy Absorption and +10% for max Reaction Load  
 ※Special rubber compound can be available at request  
 ※The data are subject to change without notice.

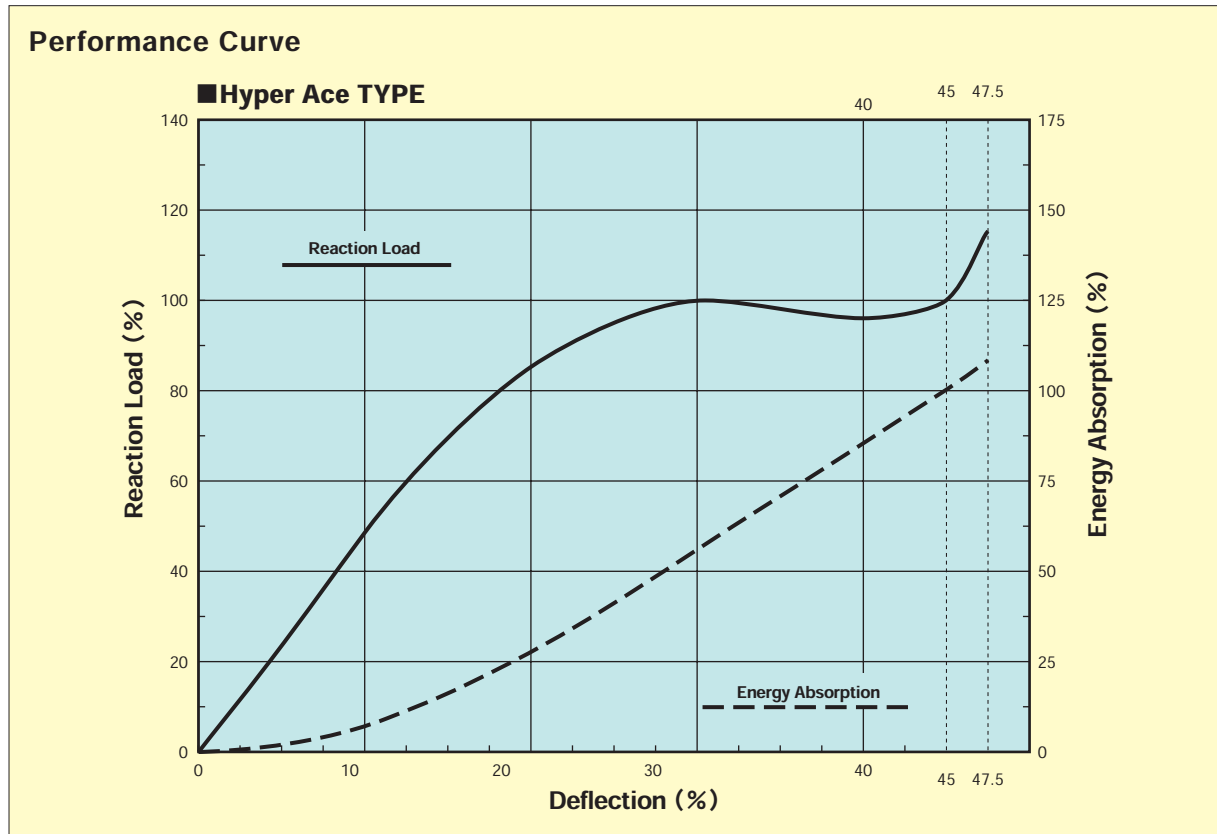

**Compression**

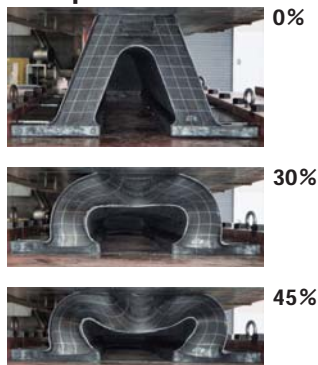

**FEM Analysis**

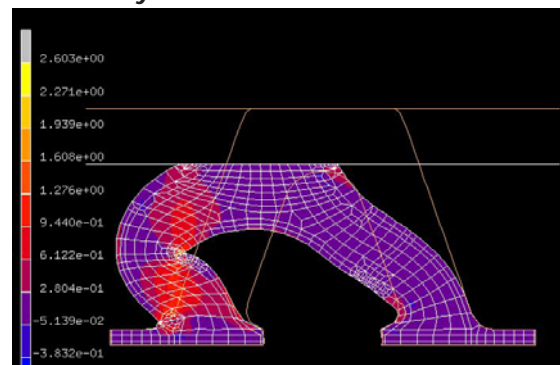





Corner Fender

Rectangular Type



HA-500Hx1250Lx1250L

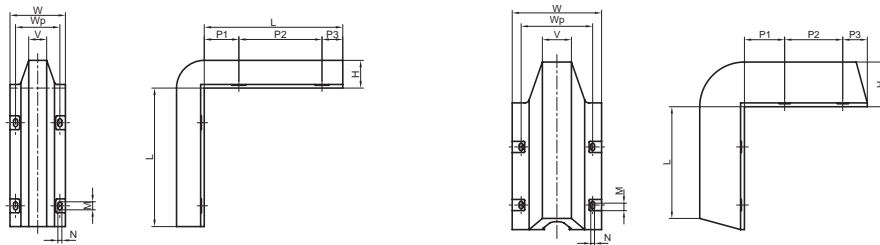

	H [mm]	L [mm]	W [mm]	Wp [mm]	V [mm]	P1 [mm]	P2 [mm]	P3 [mm]	M [mm]	N [mm]	Anchor Bolt Size & Qty	Weight [kgf]
HA-150H	150	500	300	240	98	250	200	50	50	25	M22×8	33
HA-200H	200	1000	400	320	130	250	600	150	58	29	M24×8	110
HA-250H	250	1000	500	400	162	250	600	150	58	29	M24×8	170
HA-300H	300	1000	600	480	195	350	500	150	70	35	M30×8	230
HA-500H	500	1000	1000	800	325	350	500	275	84	42	M36×8	778
HA-500H	500	1250	1000	800	325	455	650	275	84	42	M36×8	882

Corner Fender

Arc Type



HA-200Hx800R

HA-300Hx1000R

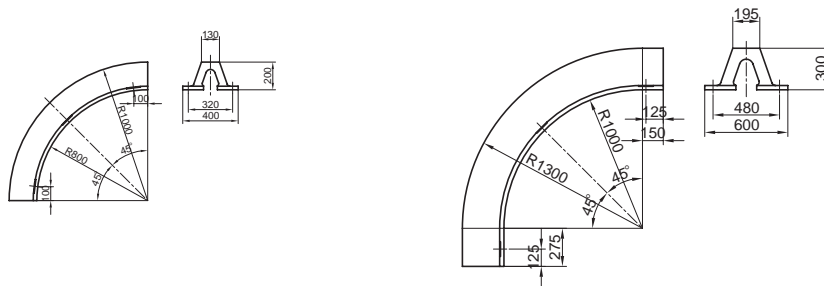

	H [mm]	W [mm]	Wp [mm]	V [mm]	Anchor Bolt Size & Qty	Weight [kgf]
HA-200H×800R	200	400	320	130	M24×6	70
HA-300H×1000R	300	600	480	195	M30×6	235



### 150H & 200H

This ladder is available in 2 different sizes, and can be made in lengths of up to 3000mm in accordance with quay wall height, tidal range, etc. If there is not enough space for installation, an HT type (extension ladder) can be bolted to GH type rubber ladder. GH.Y (Flange-less) type can be available.

### Superb Restoration

The main body and handles, composed of rubber and steel cord, are immune to permanent deformation or breakage due to impact from berthing ships. Even if deformation occurs, it will regain its original shape.

### Resistance to Corrosion

Durability and resistance to corrosion are superior to steel or stainless ladder.

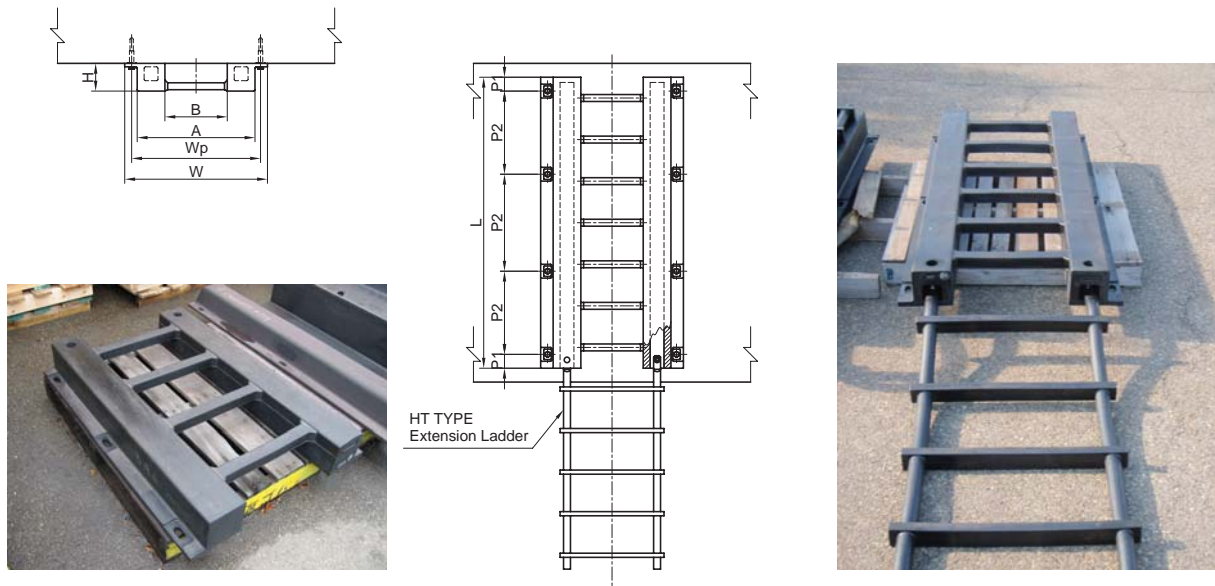

	H [mm]	L [mm]	W [mm]	Wp [mm]	A [mm]	B [mm]	P1 [mm]	P2 [mm]	Anchor Bolt Size & Qty	Weight [kgf]
GH-150H	150	900	870	810	750	450	100	700	M22×4	65
GH-150H	150	1,200	870	810	750	450	100	500 / 500	M22×6	87
GH-150H	150	1,500	870	810	750	450	100	650 / 650	M22×6	110
GH-150H	150	1,800	870	810	750	450	100	800 / 800	M22×6	130
GH-150H	150	2,100	870	810	750	450	100	600 / 700 / 600	M22×8	150
GH-150H	150	2,400	870	810	750	450	100	700 / 800 / 700	M22×8	170
GH-150H	150	2,700	870	810	750	450	100	800 / 900 / 800	M22×8	190
GH-150H	150	3,000	870	810	750	450	100	700 / 700 / 700 / 700	M22×10	220
GH-200H	200	900	1,030	930	850	450	100	700	M24×4	105
GH-200H	200	1,200	1,030	930	850	450	100	500 / 500	M24×6	140
GH-200H	200	1,500	1,030	930	850	450	100	650 / 650	M24×6	170
GH-200H	200	1,800	1,030	930	850	450	100	800 / 800	M24×6	205
GH-200H	200	2,100	1,030	930	850	450	100	600 / 700 / 600	M24×8	240
GH-200H	200	2,400	1,030	930	850	450	100	700 / 800 / 700	M24×8	270
GH-200H	200	2,700	1,030	930	850	450	100	800 / 900 / 800	M24×8	330
GH-200H	200	3,000	1,030	930	850	450	100	700 / 700 / 700 / 700	M24×10	370



Accessories

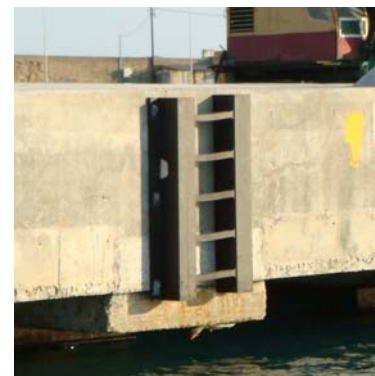
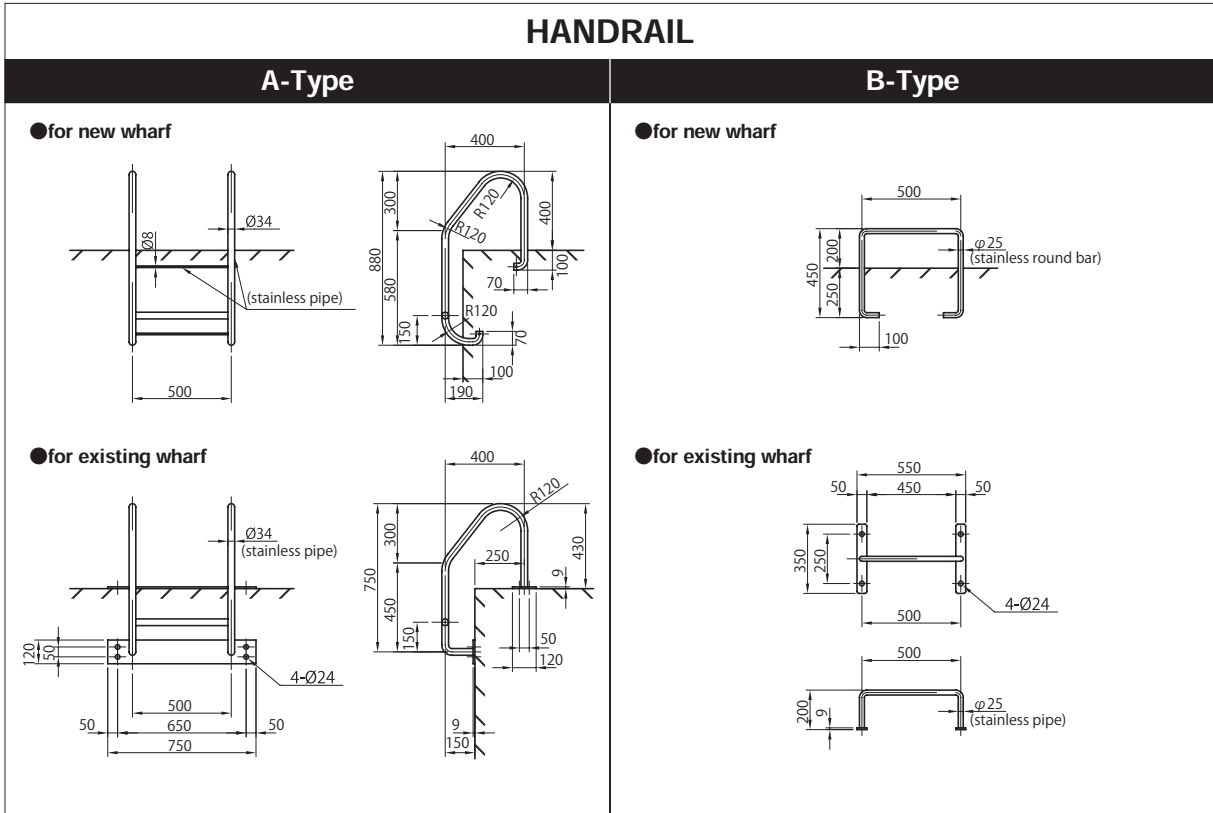

※ GH.Y (Flange-less) type



## Anchor Bolts

These bolts fix rubber marine fenders firmly to piers. Two types are available, the SMF type (for new concrete) and the resin bond-type AMC type (for existing concrete).

### Anchor Bolt SMF TYPE (for cast in)

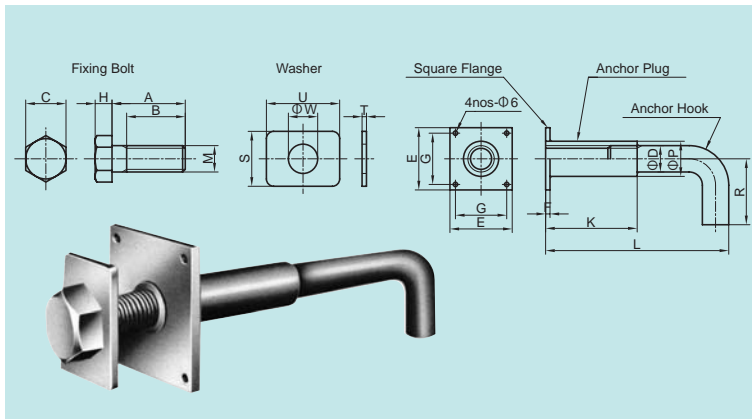

No	Part	Material	Remarks
1	Fixing Bolt	Rolled steel	Galvanized
2	Washer	Rolled steel	Galvanized
3	Square Flange	Rolled steel	Galvanized
4	Anchor Plug	Stainless steel	—
5	Anchor Hook	Rolled steel	—

Stainless steel (JIS G4303 G4305 G4315)  
Rolled steel (JIS G3101)  
Other composition of material can be available depend on design conditions.

	M [mm]	A [mm]	B [mm]	C [mm]	H [mm]	S [mm]	U [mm]	T [mm]	ΦW [mm]	ΦD [mm]	E [mm]	F [mm]	G [mm]	K [mm]	L [mm]	ΦP [mm]	R [mm]	Weight [kgf]
SMF-18	18	50	45	27	12	40	60	4.5	21	18	50	6	35	75	160	25	45	0.7
SMF-22	22	60	50	32	14	50	75	4.5	25	22	55	6	40	85	175	28	50	1.1
SMF-24	24	70	60	36	15	55	75	6	28	24	65	6	50	90	185	32	60	1.5
SMF-30	30	85	70	46	19	65	85	6	34	30	80	6	65	110	220	40	70	2.7
SMF-36	36	100	80	55	23	75	100	6	40	36	85	6	70	125	250	48	90	4.3
SMF-42	42	120	95	65	26	90	150	9	47	42	110	6	85	145	340	55	100	7.7
SMF-48	48	140	110	75	30	100	150	9	54	48	115	6	90	175	390	65	110	11
SMF-64	64	150	120	95	40	140	175	9	70	64	130	6	105	215	420	85	150	21

※The data are subject to change without notice.

### Anchor Bolt AMC TYPE (For existing concrete)

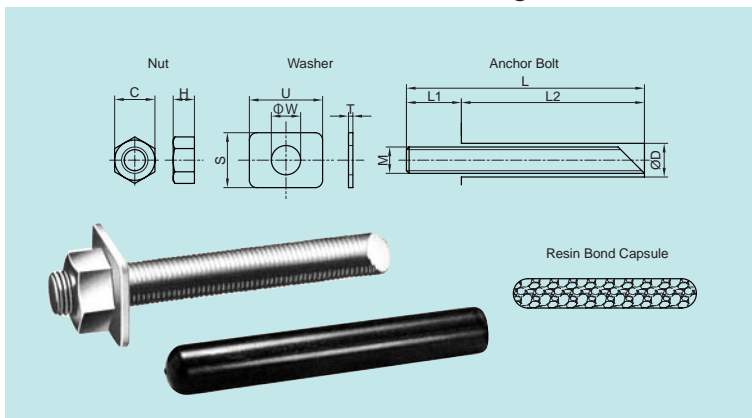

No	Part	Material	Remarks
1	Anchor Bolt	Stainless steel	—
2	Washer	Rolled steel	Galvanized
3	Nut	Rolled steel	Galvanized
4	Resin bond capsule	—	—

Stainless steel (JIS G4303 & G4305)  
Rolled steel (JIS G3101)  
Other composition of material can be available depend on design conditions.

	M [mm]	L [mm]	L1 [mm]	L2 [mm]	ΦD [mm]	C [mm]	H [mm]	S [mm]	U [mm]	T [mm]	ΦW [mm]	Resin Bond Capsule [cc]	Weight [kgf]
AMC-18	18	165	35	130	22	27	15	40	60	4.5	21	22min	0.4
AMC-22	22	195	45	150	28	32	18	50	75	4.5	25	47min	0.7
AMC-24	24	210	50	160	30	36	19	55	75	6	28	55min	0.9
AMC-30	30	270	60	210	38	53.1	24	65	85	6	34	120min	1.6
AMC-36	36	325	75	250	46	63.5	29	75	100	6	40	215min	2.8
AMC-42	42	380	90	290	55	75	34	90	150	9	47	379min	5.3
AMC-48	48	435	105	330	60	86.5	38	100	150	9	54	455min	7
AMC-64	64	600	150	450	75	110	51	140	175	9	70	772min	18

※The data are subject to change without notice.



## Accessories for Fender Systems including Steel Frames

■ Steel Frames ■ Plastic Pads ■ Pad Fixing Bolts ■ Frame Fixing Bolts ■ Chain Systems

The following is a list of accessories for the fender system.



### PLASTIC PADS & FIXING

Various polyethylene materials are available depending on the level of quality required, as shown in the table of common polyethylene types below. However, in most cases, Sumitomo Rubber Industries employs recycled UHMW (ultra-high molecular weight) or recycled HMW (high molecular weight) polyethylene. By making an effort to use recycled materials, we hope to contribute to environmental conservation.

#### Mechanical Property of Plastic Pad

Characteristics & Test Code	Coloured Virgin UHMW	Regenerated UHMW Multicol Black	Coloured Virgin HMW	Regenerated HMW Multicol Black
Density in ISO1183-1	≥0.93g/cm <sup>3</sup>	≥0.94g/cm <sup>3</sup>	≥0.96g/cm <sup>3</sup>	≥0.96g/cm <sup>3</sup>
Notched Impact Strength(charpy) in ISO11542-2	≥180kJ/m <sup>2</sup>	≥70kJ/m <sup>2</sup>	≥15kJ/m <sup>2</sup>	≥10kJ/m <sup>2</sup>
Abrasion in ISO15527	100%	130-150%	400±25%	350-450%
Tensile Strength at Yield in ISO527-2,50mm/min	≥17N/mm <sup>2</sup>	≥17N/mm <sup>2</sup>	≥20N/mm <sup>2</sup>	≥17N/mm <sup>2</sup>
Breaking Elongation in ISO527-2,50mm/min	>50%	>50%	>50%	>50%
Friction PE-Metal	0.2	0.2	0.2	0.2
Hardness in ISO868/DIN53505 Shore-D, 3-s-value 6mm plate	63	63-66	65	65-67

※The data are subject to change without notice.

#### Steel Frame material

Tensile Strength (N/mm <sup>2</sup> )	JIS	BS 4360	EN 10025	ASTM
400	G3101 SS400 G3106 SM400			A36
410			S275	A572-290 A529 A633
430		Gr43		
490	G3101 SS490 G3106 SM490	Gr50	S355	

#### Paint coating system for steel frame

It is normally designed to comply with category C5-M which is specified in ISO 12944 (Paints&Varnishes-Corrosion Protection of Steel Structures by protective paint). Following coating system is our typical specification.

Surface preparation	Shotbrast SIS Sa 2.5	Shotbrast SIS Sa 2.5
Primer coat	Zincrich primer 40µm	Zincrich primer 100µm
Top coat	2-pack Epoxy 280µm	Coal Tar Epoxy 200µm
NDFT	320µm	300µm



**Chain Strings including Adjustable Link**

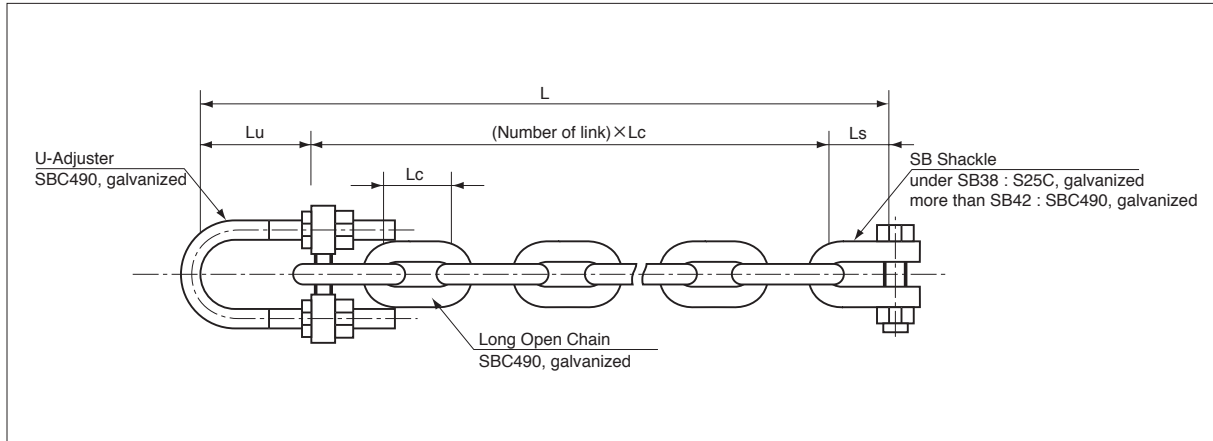

● **Table chain-1**

Nominal dia [mm]	Lc [mm]	Lu [mm]	Ls [mm]	L [mm]	Breaking Test Load [kN]
25	100	161	88	N@100+249	322.6
30	120	174	102	N@120+276	465.0
34	136	202	116	N@136+318	596.4
38	152	212	129	N@152+341	745.6
42	168	227	142	N@168+369	910.4
46	184	235	156	N@184+391	1092.8
50	200	243	170	N@200+413	1291.0
52	208	251	187	N@208+438	1396.9
54	216	251	187	N@216+438	1504.9

Note) Adjustable range is ±50mm from the standard length.  
 ※The data are subject to change without notice.

**Chain Strings with Both End Shackle**

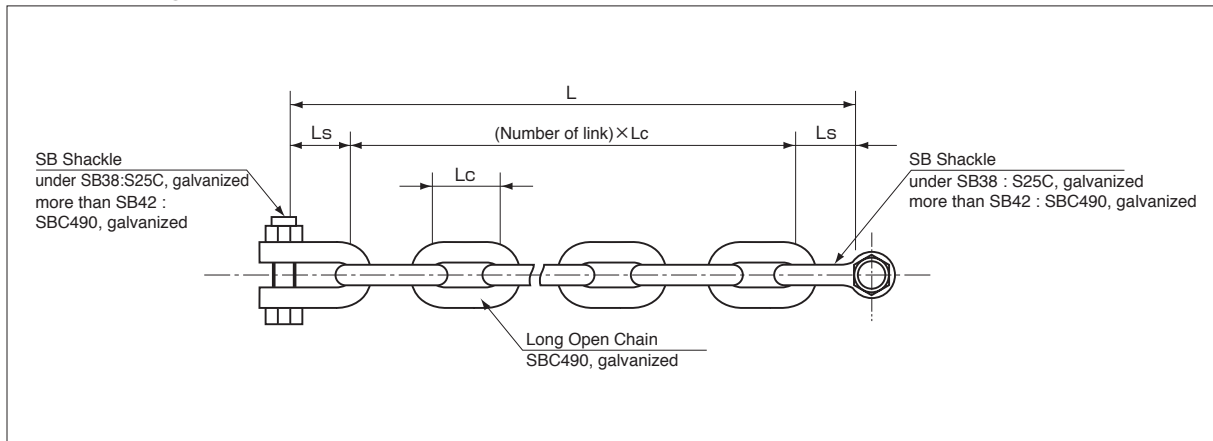

● **Table chain-2**

Nominal dia [mm]	Lc [mm]	Ls [mm]	L [mm]	Breaking Test Load [kN]
25	100	88	N@100+176	322.6
30	120	102	N@120+204	465.0
34	136	116	N@136+232	596.4
38	152	129	N@152+258	745.6
42	168	142	N@168+284	910.4
46	184	156	N@184+312	1092.8
50	200	170	N@200+340	1291.0
52	208	187	N@208+374	1396.9
54	216	187	N@216+374	1504.9

※The data are subject to change without notice.



## U-ANCHOR

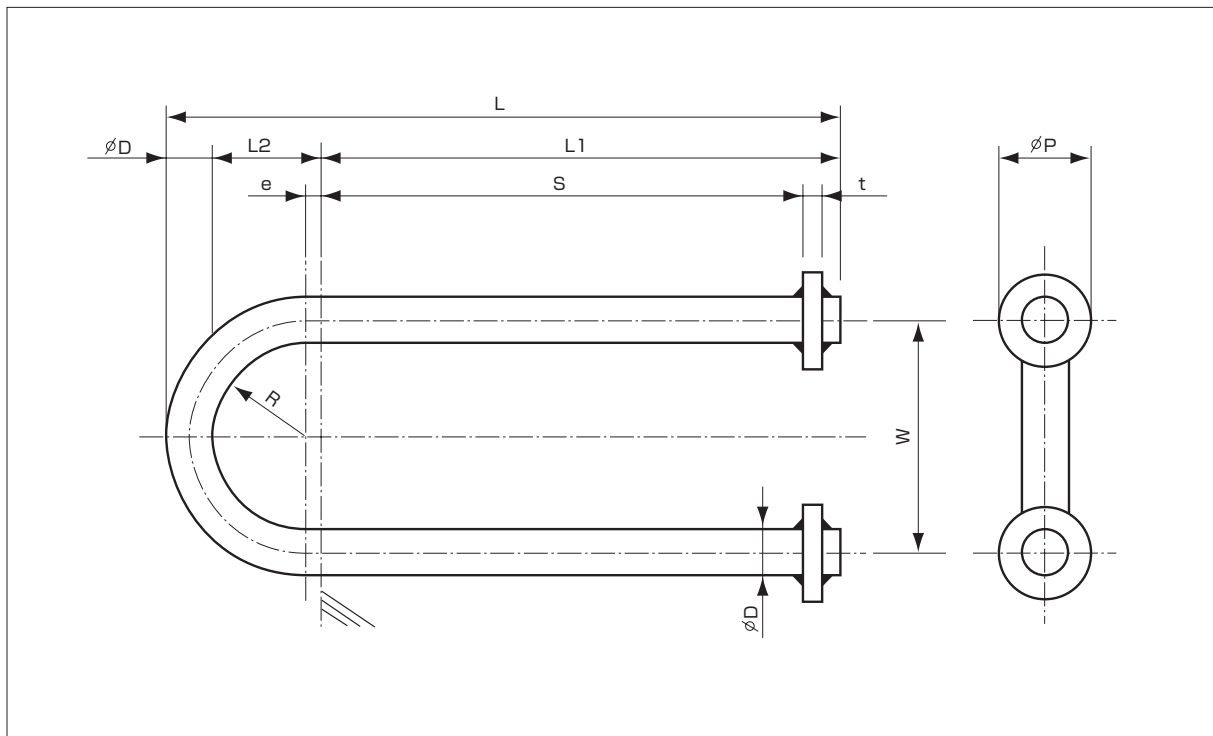

●Material: Japanese Industrial Standard (JIS G3101) SS400, HOT DIP GALVANIZED  
Other material is available as condition demands.

Metric:mm

Diameter of Chain [mm]	L [mm]	L1 [mm]	L2 [mm]	ΦD [mm]	e [mm]	S [mm]	t [mm]	R [mm]	W [mm]	ΦP [mm]
25	520	390	94	36	24	360	16	70	176	70
30	640	485	113	42	28	445	19	85	212	80
34	720	550	122	48	27	510	22	95	238	100
38	820	630	135	55	25	585	25	110	275	110
42	870	670	140	60	20	620	28	120	300	120
46	940	720	155	65	25	670	28	130	325	130
50	1000	760	170	70	30	700	32	140	170	140
52	1090	820	195	75	45	760	32	150	187	150
54	1150	870	200	80	40	800	36	160	400	160

※The data are subject to change without notice.

## Pneumatic Fender



This is ideal in the situations where a fixed fender is not applicable such as to ship-to-ship operations off shore and some ship-to-wharf operations. It is also suitable for the use at a quay where the tidal range is large. Like the hollow cylindrical fender, its initial reaction load is low at the early stage of compression and its cushion effect is virtually independent from an approaching angle of a ship. Size range: 0.3~3.3m o/d

### Portfolio of Pneumatic Fender



## Hollow Cylindrical & D-Shape Fender



### Merits of Hollow Cylindrical and D-TYPE FENDER

H.C. type fender is the fundamental rubber fender in the simple shape of hollow cylinder. The standard ratios between outside and inside diameters are 2 to 1 and 1.75 to 1. Compared with other type of fenders, it has the lower spring constant at the earlier stage of its deflection, and is easily deformed until it is compressed to close its bore. In other words, it can be largely deformed at the stage where the reaction load is low. For installation, the anchor bolt arrangement is not necessary to be so precise.

D-type fender displays higher energy absorption capacity. It can be mounted on quay wall by means of anchor bolts. It is also applicable to the working ship, small size ship, etc. (Standard Size:  $D = H$ ,  $d = 1/2H$ )

### Portfolio of Hollow Cylindrical and D-TYPE FENDER

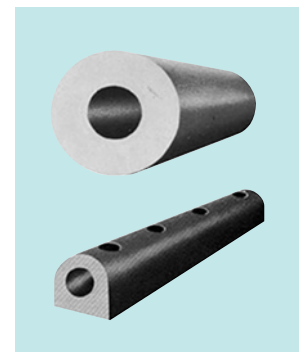



## Rubber Properties

The rubber compound is superior, especially in resistance to aging, seawater, weathering and friction. Being reinforced with carbon black, it shows the excellent physical properties as enumerated below.

### Rubber Properties

PROPERTY	Test standard and condition		Criterion	Equivalent International standard		
				ASTM	BS ISO	DIN
Tensile Strength	JIS K6251 No.3 Dumbbell	Before ageing After ageing 70°Cx96hrs	16 MPa Min. More than 80% to original	D412	BS ISO 37 BS 903 A2 *1	DIN 53504
Elongation		Before ageing After ageing 70°Cx96hrs	350% Min. More than 80% to original			
Hardness	JIS K6253 Durometer A	Before ageing After ageing 70°Cx96hrs	82 max. Less than +8 to original	D2240	BS ISO 48 BS 903 A26 *1	DIN 53505
Ageing	JIS K6257	70°Cx96hrs		D573	BS ISO 188 BS 903 A19 *1	DIN 53508
Compression set	JIS K6262	70x24hrs	30% Max.	D395	BS ISO 815-1 BS 903 A6 *1	DIN 53517
Tear Resistance	JIS K6252	Crescent type	70N/mm Min.	D624	BS ISO 34-1 BS 903 A3 *1	DIN 53507
Abrasive Wear	JIS K6264	Akron Method	1.5cc Max.	D5963-04	BS ISO 4649 BS 903 A9	DIN 53516
Bond Strength	JIS K6256-2	90 degree	7N/mm Min.	D429	BS 903 A21.1	
Seawater Resistance	JIS K6258	3% NaCl solution 23°Cx24hrs	Volume change +10%/-5% Max. Hardness change ±10 Max.	D471	BS ISO 1817 BS 903 A16 *1	
Ozone Resistance	JIS K6259	50pphm 20% elon. 40°Cx72hrs	No crack	D1149	BS ISO 1431-1 BS 903 A43 *1	DIN 53509
Density	JIS K6268		1.10 g/cc to 1.30 g/cc	D1817	BS ISO 2781 BS 903 A1 *1	

\*1 Previous BS standards are superseded  
 ※The data are subject to change without notice.

The followings are the definitions of Technical Terms for SUMITOMO Fenders.

**(1) The end shape of fender**

According to the appearance of them, the fenders are classified as follows.

**(1-1) Tapered end : KT**

The fender having the tapered ends.  
The standard taper in 1/4 of fender height.  
The code for this type is "KT"

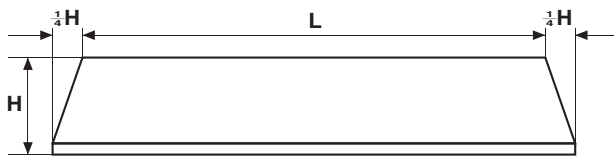

**(1-2) One end is cut into straight : KF**

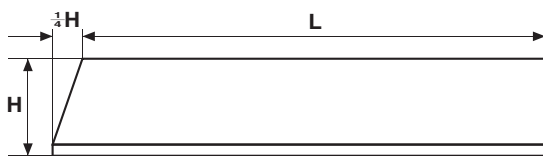

**(1-3) The both ends are cut into straight : FF**

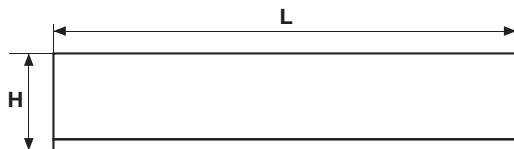

**(1-4) Masked one end Blind : KTM**

One end is made blind of KT

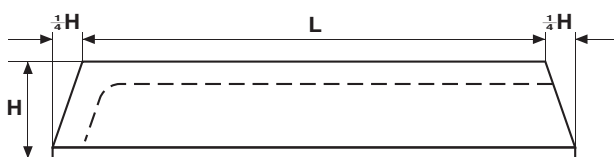

**(1-5) Splayed tapered end : ST**

An end is tapered with 32.5 degree for prevention of ship's riding.

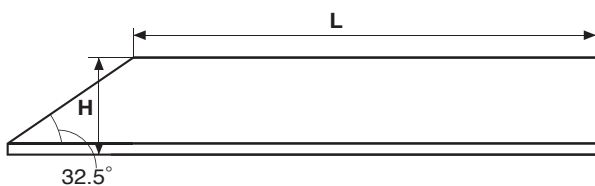

**(1-6) Masked splayed end blind : STM**

One end is masked blind of ST

**(2) Size indication**

A fender size is indicated as follows by way of example.

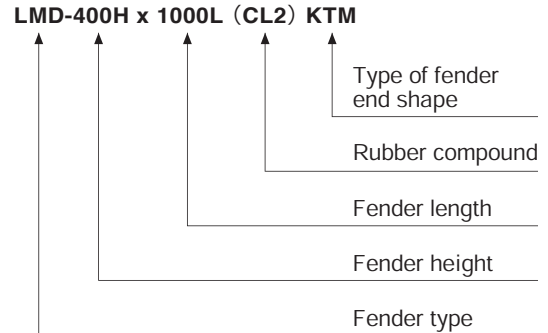

**(3) Tolerance**

Item	Dimansion	Tolerance
Fender	Length, Width and Height Bolt hole spacing Bolt hole diameter	+4%, -2% ±4 mm ±2 mm
Steel Frame	Length and Width (< 3 m) Height (< 3 m)	±5 mm ±10 mm ±2 mm
Plastic Pad	Length and Width Thickness (49 mm) (50-99 mm) (100 mm) Bolt hole spacing Bolt hole diameter	±3 mm ±1 mm ±1 mm ±3 mm ±1 mm ±0.5 mm

**(4) Deflection**

**(4-1) Rated deflection**

A stage of fender deflection at which the performance efficiency, the ratio of energy absorption to reaction load, becomes the largest.

**(4-2) Maximum deflection**

The maximum limit of fender deflection up to which a fender can be deflected in excess of the rated deflection with no troubles.

**(5) Performance data**

Compression performance data in this catalogue is not RPD. Please contact us for further information.

# PROJECT REQUIREMENTS FOR DESIGNING FENDER SYSTEM

## GENERAL

Project

Port

Country

Contractor

Consultant

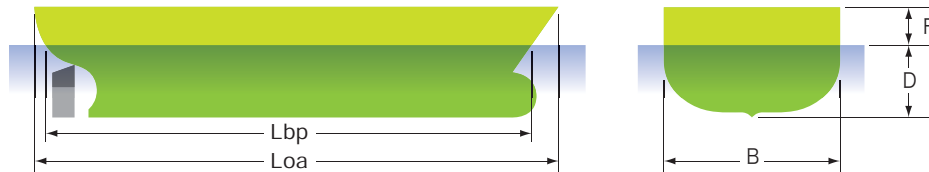

## VESSEL DETAILS

	Maximum vessel	Minimum vessel
Vessel type		
Deadweight	(ton)	(ton)
Displacement	(ton)	(ton)
Length Overall (Loa)	(m)	(m)
Length between perps (Lbp)	(m)	(m)
Beam (B)	(m)	(m)
Draft (D)	(m)	(m)
Freeboard (F)	(m)	(m)
Hull pressure	(ton/m <sup>2</sup> )	(ton/m <sup>2</sup> )
Ship's belt		

## BERTHING CONDITIONS

	Maximum vessel	Minimum vessel
Berthing mode	Side berthing · Dolphin berthing · End berthing · Other	Side berthing · Dolphin berthing · End berthing · Other
Berthing speed	(m/sec)	(m/sec)
Berthing angle	(deg)	(deg)
Abnormal berthing factor		

## BERTH DETAILS

Structure	Elevation
Quay Type	Tidal range (m)
	Highest astronomic tide (HAT) (m)
	Mean high water spring (MHWS) (m)
	Mean sea level (MSL) (m)
	Mean low water spring (MLWS) (m)
Length of Berth (m)	Lowest astronomic tide (LAT) (m)
Fender or Dolphin spacing (m)	Installation area - Top (X) (m)
Allowable fender reaction (kN)	Installation area - Bottom (Y) (m)

### Fender Position

Steel frame - Top (Ft)	(m)
Center of Rubber fender (Fc)	(m)
Steel frame - Bottom (Fb)	(m)
Width of steel frame (Fw)	(m)
Stand-off (St)	(m)

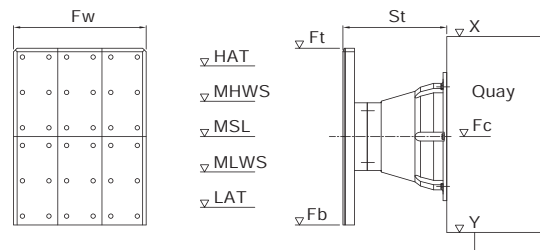

## FURTHER INFORMATION AVAILABLE FORM

Name	Tel
Position	Fax
Company	
E-mail	Address

 **SUMITOMO RUBBER INDUSTRIES, LTD.**

**Hybrid Rubber Products HQS.**

**TOKYO OFFICE**

1-1-8, Nihonbashi-Kayabacho, Chuo-ku, Tokyo, 103-0025, Japan  
Tel : +81-3-5614-8261, Fax : +81-3-5614-8277  
E-mail: [civil@sri.dunlop.co.jp](mailto:civil@sri.dunlop.co.jp)  
<http://www.civil-works-sri.com/>

**DUBAI OFFICE**

Office No.5WA 118, Dubai Airport Free Zone,  
P.O.Box 54901, Dubai, UAE  
Tel : +971-4-214-6947, Fax : +971-4-214-6960

For better choice of the Fender System,  
please contact our sales representative.

---

Presented by

---